



User Guide

Loadsensing G7 Wireless Tiltmeter (Tilt-XHP & Tilt-IR)

LSG7ACL-BXLH-TIL & LSG7ACL-BILR-TIL



www.worldsensing.com



www.worldsensing.com | support@worldsensing.com

© 2025 Worldsensing. All rights reserved. Version 2.

Document version	Date	Description
Version 1.0	June 2025	First edition of the Loadsensing G7 Tiltmeter - Feature parity with G6
Version 2.0	January 2026	Loadsensing G7 Tiltmeter

Table of contents

1. Important instructions prior to use.....	3
1.1. General warnings.....	3
2. Glossary.....	3
3. Device overview.....	5
4. Device Specifications.....	6
5. System requirements.....	6
6. Equipment provided.....	7
7. Wireless tiltmeter remarks.....	10
8. Wireless tiltmeter installation.....	10
9. Operational modes.....	12
10. Powering up the device.....	14
9. Loadsensing Device Configuration.....	15
10. Safely Closing the Device.....	18
11. Tiltmeter axes orientation.....	19
12. Calibration.....	21
13. Device and data management through CMT Edge.....	22
14. Device and data management through CMT Cloud.....	28
15. Event Detection Mode.....	32
15.1 Overview.....	32
15.2. Operating Principle.....	33
15.3. Event detection Alert and data reporting Messages.....	35
15.4. Latency and System Performance.....	39
15.5. Transmission Reliability, Radio Network Characteristics and Coverage.....	40
15.6. Integration with External Systems.....	42
15.7. Remote Configuration and Device Management.....	42
15.8 Requirements and Recommendations for Successful Deployment.....	50
16. Maintenance and troubleshooting.....	51
17. Battery Life Estimates.....	52
18. Data storage.....	54
19. Formats.....	56
20. FAQs.....	57
21. Environmental best practices.....	59
Appendix A. Axis convention while installing the device attached vertically and horizontally.....	61
Appendix B. CALIBRATION SHEET.....	68
CONTACT WORLDSENSING.....	69

1. Important instructions prior to use

Please read these instructions carefully and ensure that the required conditions specified in this document are met before using the product. Each of our edge devices includes this information inside the packaging.

1.1. General warnings





Follow these precautions to avoid a battery explosion or leakage of flammable liquid or gas:

- Use the correct battery type. Dispose of the batteries according to instructions. Do not dispose of the batteries by throwing them into a fire or a hot oven, or mechanically crush or cut them.
- Do not leave the batteries in an extremely high-temperature environment. Do not subject the batteries to extremely low air pressure. It may result in an explosion or leakage of flammable liquid or gas.
- Do not short circuit the batteries. This will blow the protection fuse.

Batteries and equipment to be connected via the data port must meet IEC 62368-1 ES1 and PS1 requirements.

Equipment to be installed in restricted access areas.

Table 1 : general warning information

Symbol	Description
	Caution. Do not proceed until the instructions are clearly understood and all required conditions are met.
	Read the instructions for use carefully before using.
	Caution, hot surface.
	According to the European Union WEEE Directive 2012/19/EU, this product and its batteries should not be discarded as unsorted waste. Please send them to separate collection facilities for recovery and recycling. It is your responsibility to dispose of your waste equipment and batteries properly. The correct disposal of your old equipment and batteries will help prevent potential negative consequences for the environment and human health.

2. Glossary

Sample: One single measurement of the sensor.

Sampling rate: Number of times information from a sensor (sample) is collected per unit of time. In other cases this would be given in Hz, but given that in Loadsensing systems frequencies are small (for example, 0.00027 Hz is once every hour), it is used interchangeably as Sampling period.

Sampling period: Time between two sensor information collections. ($1/\text{Sampling rate}$). It is used interchangeably as Sampling rate.

Reading: Complete Data from a certain timestamp. A line in the Readings CSV file. Depending on the sensor type, the 'reading' can be directly a single sample of the sensor or can be the result of averaging a set of measurements. With the exception of the alert messages which are not readings, there is a delay between the reading and the transmission. This delay is a random value within the slot time.

Operational Modes: different remotely configurable operational modes adapted to different applications while optimizing power consumption. Amongst them are periodic, triggered and Event Detection Modes.

Environmental sensors: Dedicated embedded temperature and humidity sensors inside the logger

Event Detection Solution: Set of items which work together to offer the features presented in this guide.

Event Detection Mode (EDM): Specific way of operation for a TIL90 which enables real-time alerting when an event occurs.

Periodic Reading (in normal/alert state): Data which is gathered at synchronous intervals defined by configuration.

Reporting Period: Time between two acquisitions of synchronous readings.

Radio message: One single transmission from the edge device to the Gateway or from the Gateway to the edge device. To transmit a 'reading', one (e.g. wireless tiltmeter) or more than one radio message (e.g. digital logger connected to a dozen of in-place inclinometers) can be required.

Normal State: Normal status of the device, when the values of tilt are in between the upper and lower thresholds.

Alert-to-normal Stoppage time: time the values must be between the thresholds before the alert state is disabled.

Alert State: Mode enabled when at least one axis is outside the threshold limits until a stoppage time has passed.

Alert message: Triggered Real time message when a threshold is broken. Does not consider the slot times.

Continuous sampling for event detection: Data gathered from a TILT90 sensor at a Sampling rate of 3.9 Hz.

Alert triggered reading: Data which is generated because a threshold is broken or normal state has been reached back. Standard deviation will be 0 as only one sample is reported.

Latency: In Loadsensing applications, latency refers to the time delay between a measurable physical change in the system being observed and output clearly discernible to the data management and visualization software. In the event detection solution, latency refers to the time delay between an event occurrence (tilt exceeding a preset threshold) and the delivery of the alert messages on the MQTT/Modbus TCP client.

3. Device overview

This user guide describes the new Loadsensing wireless G7 Tiltmeter, hereinafter referred to as **Tilt-XHP** and **Tilt-IR**. It explains the main features available as well as the procedures for configuration and operation. Additional technical details can be found in the corresponding [datasheet](#).

The **Tilt-XHP** and **Tilt-IR** are long-range, low-power wireless data loggers equipped with a main accelerometer that provides 3-axis tiltmeter. These devices measure three-axis inclination relative to the direction of gravity and report the two axes of rotation with respect to the horizontal plane, regardless of installation orientation.

The tiltmeter devices also incorporate secondary sensors, including a low-power accelerometer that continuously samples at a high rate and enables functionality across different operational modes as well as [environmental sensors](#), such as dedicated temperature and humidity sensors.

Two models are available, each with a new product codification:

- **LSG7ACL-BXLH-TIL:** Tiltmeter node with external LoRa antenna and high-precision accelerometer, marketed as Tilt-XHP.
- **LSG7ACL-BILR-TIL:** Tiltmeter node with internal LoRa antenna and low-precision accelerometer, marketed as Tilt-IR.

The devices have the X, Y, and Z axes engraved on the enclosure, allowing users to easily identify the measured axes during installation in any orientation.

The G7 Tiltmeters can operate either connected to the CMT or as standalone data loggers for manual monitoring. Configuration is straightforward and can be performed by connecting the device to an Android smartphone using a USB Type-C cable.

The G7 Tiltmeter supports configurable operational modes to adapt to different applications while optimizing power consumption:



- **Periodic Mode** enables regular, long-term monitoring with extended battery life.
- **Triggered Measurements Mode** captures data based on predefined activity thresholds, reducing unnecessary transmissions.
- **Event Detection Mode** provides continuous monitoring with low-latency reporting for early warning system (EWS) applications.

Tiltmeters used in monitoring applications measure deviations from the vertical level in both ground and structural installations. As a result, they are key sensors for monitoring **inclinations, movements, and differential settlements** in slopes and infrastructure.

These devices have been widely used in **landslide monitoring, embankments, and mining applications** to assess and control slope stability.

4. Device Specifications

Please refer to the [datasheet](#)

5. System requirements

Tilt-XHP and Tilt-IR are:

- Available from version 3.13 onwards
- Need to be configured by using the Worldsensing App firmware version 2.13.1 onwards
- CMT Edge version: from firmware version 2.10.1
- CMT Cloud version: from firmware version 2.10 onwards

6. Equipment provided

As mentioned above, there are two wireless tiltmeter variants: Tilt-XHP and Tilt-IR.



Figure 1: Tilt-XHP view

Device components from TILT-XHP:

- A. Hybrid enclosure 100x100x61 mm: aluminium base and plastic lid
- B. External LoRa antenna
- C. Antenna elbow adapter
- D. SMA antenna connector
- E. Pressure stabilizer for protection against condensation (protective vent)
- F. USB type C internal connector

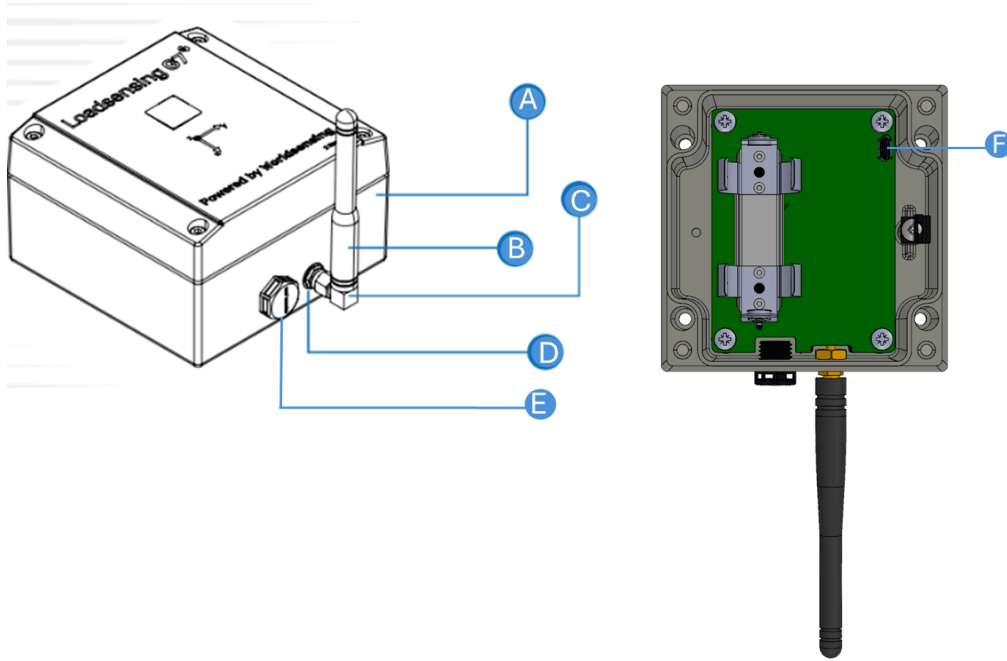

Figure 2: Device components from TILT-XHP

When ordering the wireless Tilt-XHP all these components are included.

Device components from Tilt-IR:

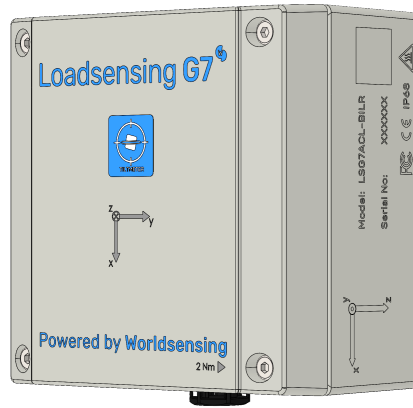

Figure 3: Tilt-IR view

- A. Internal LoRa antenna
- B. USB type C internal connector
- C. Battery holder
- D. Pressure stabilizer for protection against condensation (protective vent)

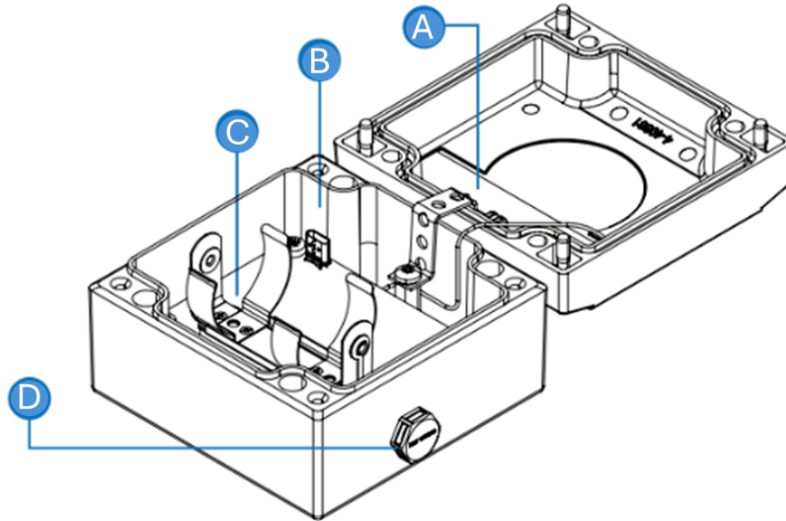

Figure 4:Tilt-IR elements

The following elements are sold separately for both tiltmeters:

- Mounting supports. See the mounting instructions for each support
- USB C-USB C configuration cable (WS-ACC-G7-USBC)
- Batteries (WS-ACC-CELL-1D)

Please note that this device is produced without blind holes for M5 screws on the lateral side, which makes it no longer compatible with the Mounting Plate for Vertical Mounting (LS-ACC-IN15-VP)

7. Wireless tiltmeter remarks

Arrows have been included on the lid for both models. The sign convention has been preserved by referencing either the antenna (in the case of LSG7ACL-BXLH-TIL) and the Gore valve, both located on the same side, or the side with the barcode and serial number.

Please check the Appendix A for reference.

8. Wireless tiltmeter installation

The first task of getting your Loadsensing Tiltmeter node up and running on your site is to install it. There are three major factors to consider when installing the node: the various supports you might use, the mounting of the Tiltmeter node, and powering the node once it is installed. We discuss each of these three here.

The Tiltmeter node must be mounted on a suitable support. In most applications, the device can be installed **directly aligned with the monitored surface**. A **horizontal surface mounting plate** may be used for both horizontal and vertical installations, depending on the application requirements.

To reduce thermal effects and measurement noise, tiltmeters on vertical surfaces should be mounted with minimal overhang. The 100 × 100 mm base should be fixed directly to the support in full contact with the monitored structure.

This installation approach helps to:

- Minimize thermal effects by increasing the contact area with a structure that has higher thermal inertia.
- Reduce temperature gradients within the device.
- Minimize measurement noise introduced by mechanical effects associated with the overhang.

For concrete structures, brick walls, and similar materials, and when anchors are required, we recommend using threaded rods fixed with chemical anchors or grout mortar.

Expandable anchors may introduce additional thermal effects and are therefore not recommended.

Further information and detailed drawings can be found in the accessory user guides.

Several mounting solutions are available to accommodate different installation scenarios:

Description	Code
Versatile plate for horizontal surface mounting recommended for both horizontal and vertical mounting; attachment option: anchor rods or glue. Includes a threaded hole available for installing a monitoring prism or a button head screw for precise leveling.	LS-ACC-IN15-HP
Horizontal surface mounting plate for track monitoring; attachment option: glue.	LS-ACC-IN-HPTM
Versatile double plate for horizontal surface mounting (includes a threaded hole for a prism or a button head screw, for precise leveling)	LS-ACC-IN15DP
L-shaped mounting plate for pole installation. Attachment options: 50 mm U-bolts for pole fixing (or anchor rods for vertical mounting) ¹	LS-ACC-LVP
1 meter aluminium beam with specific profile to attach a Tiltmeter XHP/Tiltmeter IR	WS-ACC-1BEAM
2 meter aluminium beam with specific profile to attach a Tiltmeter XHP/Tiltmeter IR	WS-ACC-2BEAM
Mounting plate for magnetic fix to structures, enabling faster and simpler installation.	LS-ACC-G7-VP

¹ This mounting plate can be used for some applications, but it will be important to take into account that using it will affect the quality of the data.



Compatibility Note

Most **G6** accessories are compatible with the G7 Tiltmeter range, **except for the vertical plate (LS-ACC-IN15-VP)**, which is not supported.

9. Operational modes

The new G7 Tiltmeters support multiple operational modes, allowing them to be adapted to a wide range of applications while optimizing power consumption.

These operational modes are available for both Edge and Cloud architectures and are configured exclusively through the CMT. One of the main advantages of the Loadsensing system is the ability to configure and update these modes remotely.

This remote configuration capability removes the need for on-site reconfiguration and provides greater flexibility to accommodate changing application requirements or operational conditions within the same project phase.

The operational Modes of the G7 Tiltmeter are presented below:

Periodic Mode

The Periodic Mode represents the classic Loadsensing operation, in which the node takes measurements at regular, predefined intervals. In this mode, the sensor performs periodic readings based on a static reporting period, configurable from 30 seconds up to 24 hours.

This operational mode is well-suited for consistent, long-term data collection. Its main advantage is extended battery lifetime, making it ideal for applications that require continuous monitoring without frequent data transmission.

Triggered Measurements Mode (TMM)

In Triggered Measurements Mode, readings are taken when specific conditions are met. The G7 Tiltmeter uses the embedded low-power accelerometer, which has the same orientation than the main accelerometer, to detect activity by monitoring changes in different physical magnitudes.

In this mode, data is collected at regular intervals and additionally when a user-defined threshold is exceeded. This approach helps reduce unnecessary data transmissions while maintaining a low impact on battery life.

The physical magnitudes that can be configured to trigger events include:

- **Absolute angle variation:** the orientation or tilt of the device relative to a reference position
- **Angular velocity:** the rate of rotation around an axis, derived from angle variation
- **Acceleration:** deviation between the current measurement and the expected value (in mg)
Data is collected at regular intervals and when a user-defined threshold is exceeded, reducing unnecessary data transmissions while preserving battery life.

Further details are available in the Help Center:

[G7 – Triggered Measurements \(TM\) Operational Modes](#)

When operating in **Absolute Angle** mode, differences may be observed between standard tiltmeter readings and the angles reported in TMM statistics. Standard readings use the main accelerometer and are calibrated, whereas triggered measurements use uncalibrated angle data, resulting in an expected offset.

Additionally, the angle data used for TMM has lower repeatability and resolution than standard tiltmeter measurements. When a trigger condition is met, a full tiltmeter measurement is activated and transmitted.

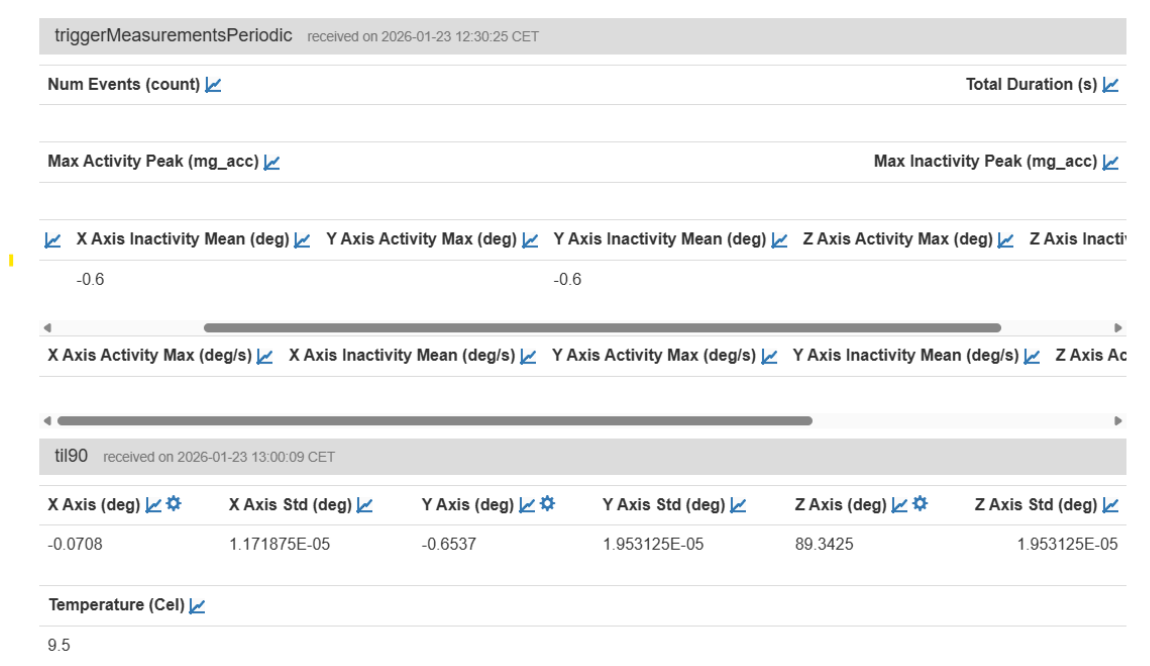

Figure 5: Example: The Absolute Angle reported in the TMM statistics at 12:30:25 CET was -0.6° , -0.6° , and 89.2° (X, Y, Z), while the corresponding main tiltmeter reading at 13:00 CET was -0.0708° , -0.6537° , and 89.3425° (X, Y, Z).

Event Detection Mode

The Event Detection Mode is available by default and is configurable on all G7 Tiltmeter devices. This mode is specifically designed for Early Warning Systems (EWS) and ensures low-latency data transmission by using MQTT. (< 2 seconds).

In this mode, the main tiltmeter sensor operates continuously in dynamic measurement mode (3.9 Hz), with data being constantly evaluated against axis-specific thresholds to promptly detect and report critical events.

More information about how to set up them but also the different parameters that can be configured can be found on chapter 15.



Triggered Measurements and Event Detection modes cannot be used at the same time. Enabling one mode automatically disables the other. A confirmation from the node is required whenever either mode is enabled or disabled.

Powering up the device

The G7 tiltmeter is designed to operate using D-type batteries, specifically the SAFT LSH20 model. While other D-type batteries may be physically compatible, please review the following important guidelines and limitations:

- **Certified Performance and Safety:**

The Tilt XHP and IR and SAFT LSH20 battery combination has been thoroughly tested and certified for electrical safety and performance. All specifications (including battery life and peak current capabilities) are based exclusively on SAFT LSH20 testing.

- **Alternative Battery Use:**

Alternative D-type batteries may only be considered if they meet the following criteria:

- Must be certified in accordance with IEC 60086 (the international standard for primary batteries).
- Must use spiral cell lithium-thionyl chloride (Li-SOCl₂) technology, which is essential for delivering the high peak currents required by the G7 node without degrading battery lifespan.

- Even when these requirements are met, performance and longevity may differ from the values specified in Worldsensing documentation, which are based solely on SAFT LSH20 testing.

- **Warranty and Liability Notice:**

- The use of unsupported or non-compliant batteries is strictly prohibited.
- Doing so will void the device warranty.
- Worldsensing assumes no liability for damage, malfunction, or safety issues resulting from the use of batteries that do not meet the stated specifications.

- **Battery Configuration:**

- Only one D-type battery may be connected to the G7 node at any time.
- Use of multiple or improperly connected batteries may result in device failure or safety hazards.

For optimal performance, safety, and warranty coverage, only the SAFT LSH20 D-type battery is officially supported.

Please contact our technical support team if you require further clarification or evaluation of alternative battery models.

Please note that the device has reverse battery protection but it is not safe to keep batteries reversed in the device for a long time.

The Loadsensing wireless tiltmeter does not have a real-time clock battery to keep time, so it is very important for the device to be powered with batteries when the time is set during installation. Otherwise, the device will default to the year 1970 and data will not appear in the CMT.

Please consider that the Tiltmeter can only be powered by batteries.

General warnings

- Follow these precautions to avoid a battery explosion or leakage of flammable liquid or gas:
 - Use the correct battery type. Dispose of the batteries according to instructions. Do not dispose of the batteries by throwing them into a fire or a hot oven, or mechanically crush or cut them.
 - Do not leave the batteries in an extremely high-temperature environment.
 - Do not subject the batteries to extremely low air pressure. It may result in an explosion or leakage of flammable liquid or gas.
 - Do not short circuit the batteries. This will blow the protection fuse.
- Batteries and equipment to be connected via the data port must meet IEC 62368-1 ES1 and PS1 requirements.
- Equipment to be installed in restricted access areas.

9. Loadsensing Device Configuration

We strongly recommend configuring the Loadsensing device on location so you can conduct an on-site radio coverage test at the same time.

Device configuration has to be carried out using the Worldsensing Android app.

Please note that G7 generation nodes have USB C connector, so for configuring the node a USB C to USB-C cable must be used with the Android device. Please refer to code WS-ACC-G7-USBC, when ordering the cable.

Please refer to the [Worldsensing app User Guide](#) for more details. To make sure the app works properly, we recommend purchasing one of the mobile phone models in stock from Worldsensing. Please contact the technical support team for more information.

WorldsensingApp starts up automatically once the Android device is connected to the Loadsensing node using a USB C-USB C cable. It does not need to be started up manually.

Please take note of the credentials in the Gateway Information Sheet as these will be necessary to perform the radio coverage test.

Specific features on the Worldsensing App for the tiltmeter are the “*set last configuration mode*”.

When deploying a big Network of Tiltmeters on-site with the same configuration, the user could use this functionality that allows applying the last completed setup configuration on the node. If there is any parameter that has a different configuration, it would be necessary to configure the node again. This functionality does not configure the Bluetooth so this particular feature must be configured individually for each node.

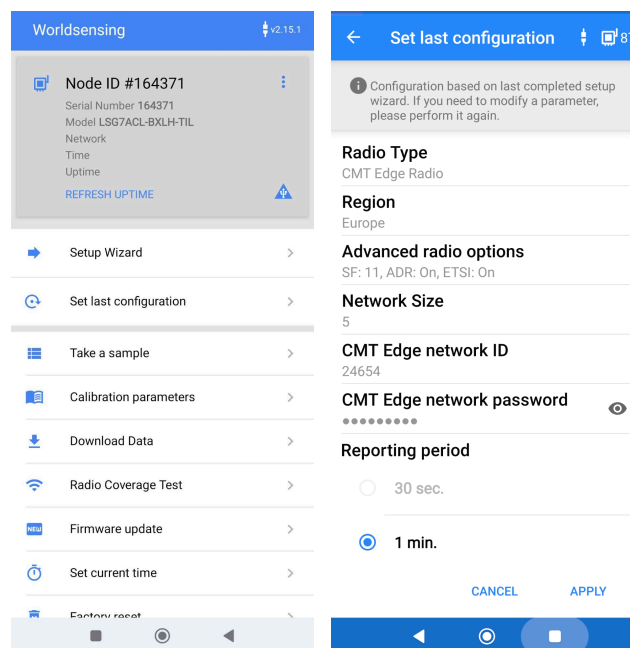

Figure 6: Worldsensing app screenshot of “use last configuration mode”

This node integrates one sensor, and it is not necessary to configure the sensor’s settings on the WorldsensingApp.

The app will show the option of taking a sample. Taking a sample will show the parameters measured and allow you to check the consistency of the readings.

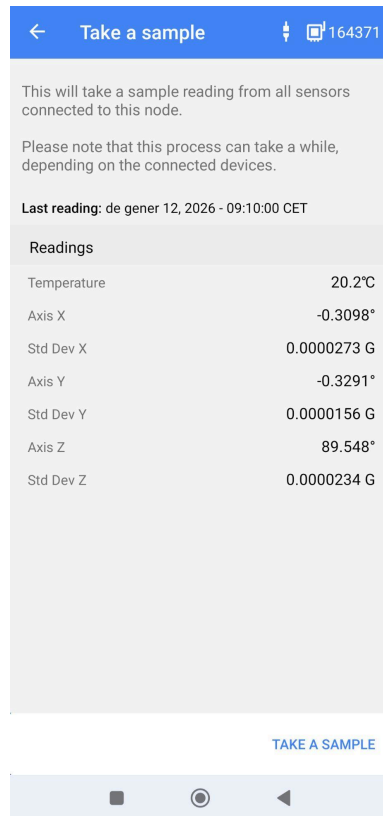

Figure 7: WorldSensing app screenshot taking a sample.

The app will show tiltmeter readings: the 3-axis inclination measurement with respect to gravity's direction, its standard deviation (expressed in Gravity) and also the internal temperature of the node.

3-axis Inclination measured by the tiltmeter is calculated as the average of a certain amount of acceleration samples in a period. At the same time the standard deviation of the sample is obtained, and it could be useful to filter anomalous readings collected by the Til90 affected by some movements.

The G7 Tiltmeter has a Built-in temperature and humidity sensor that provides more accurate temperature readings than the one used for the G6 tiltmeter and is able to detect lack of sealing or locking in the enclosure.

The specs are published on the datasheet (0,1°C sensor resolution).

As the sensor is embedded in a metallic case, the temperature readings will be highly affected by sun exposure. For those applications where monitoring the temperature of the asset is required, we strongly recommend using thermistors prepared for those specific purposes.

Do not mix this information with the temperature influence of the accelerometer data which is published in the datasheet of each device.

After taking a sample the user can go through the radio configuration steps. More information from the main steps can be found in the [WS App user guide](#).



Important Note

When configuring the tiltmeter G7 with the WS App, the device will be configured in periodic mode. Triggered and Event Detection Mode can only be configured through the CMT.

10. Safely Closing the Device

The wireless Tiltmeter has undergone watertightness testing by an external laboratory and has been rated IP68 at 2 m for 2 hours

To guarantee water tightness:

- Lock the box by tightening screws crosswise on the lid. Adjust the screws using a torque wrench. If this is not done properly, the base faces and cover may not be parallel, screwing may become more difficult and the screw threads or the Helicoil inserts may be damaged. Moreover, the O-ring (seal) may not be properly sealed and the degree of protection against water intrusion could be compromised.
- Screw the box at 2 Nm (the force that needs to be applied is marked on the outside of the device) using a torque screwdriver (e.g. Ref. 1227107 from WERA).
- Mount the antenna for model LSG7ACL-BXLH-TIL
- Make sure the sealing ring has not been physically or chemically manipulated.

Note: There is no need to seal the GORE valve to comply with IP68.

Note: Worldsensing can't guarantee the IP68 rating if any of the above conditions are not met or if one or several components (e.g. the GORE valve) are damaged.

Note that box screws shouldn't be torqued more than 2 Nm. If you exceed the torque, the Helicoil insert may be damaged. We do not recommend using electric drills or electric screwdrivers.

11. Tiltmeter axes orientation

In this chapter we will explain how the Tilt-XHP/Tilt-IR can be installed, what it measures and which parameters can be read.

It can be installed on any orientation among the 360°, it has a 90 ° range and it does not require to be installed in horizontal position. The tilt angle is calculated from a 3 axis MEMS accelerometer, reports the 3 axis inclination measurements with respect to the gravity's direction and measures the inclination of the two horizontal planes (it does not measure rotation around gravity's direction-Yaw).

Find attached a schematic of the different angle installation with respect to the 3 axis.

This specific image belongs to the former TIL90X, but the sign criteria is the same for the new Tilt-XHP/Tilt-IR. Please consider the antenna as a reference.

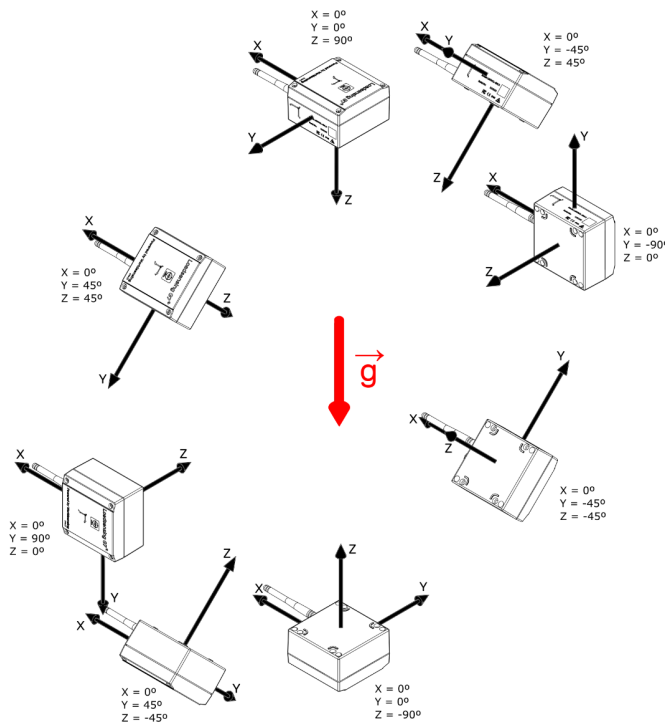

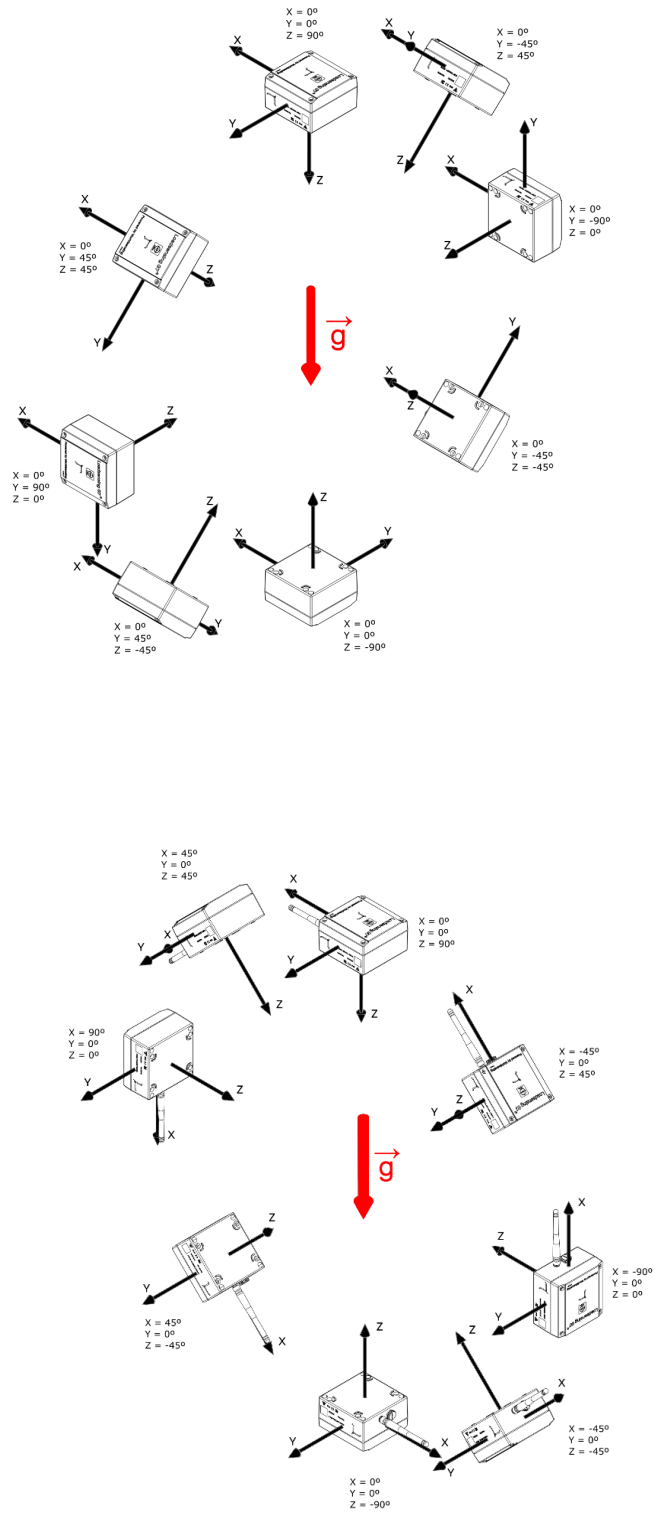

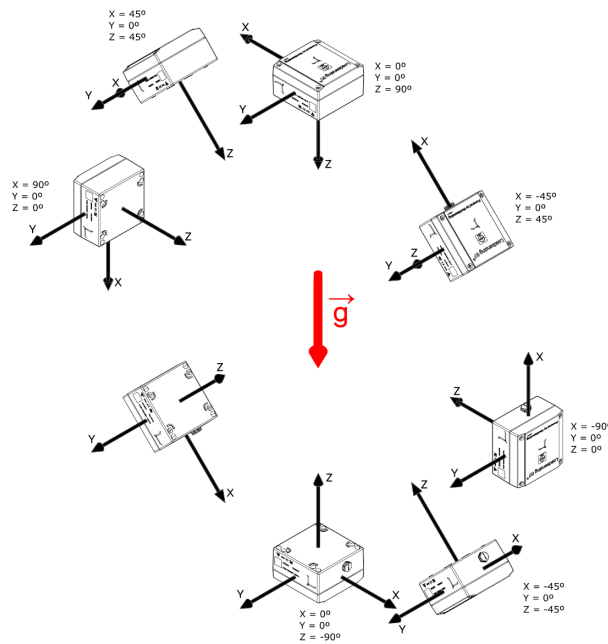

Figure 8: Values of 3 axes on different angle installations.

12. Calibration

The tiltmeter sensor is assembled, calibrated and tested under stringent quality control standards.

The coefficients for the linear equation are determined with 4 inclination steps (0, 90, 180, 270 degrees) between the XZ and YZ planes. The calibration formula is directly applied to the collected readings by the wireless tiltmeter. As a consequence, data transmitted and logged into the device is already corrected.

You can take a look to an example calibration sheet published on the article.

DO NOT REAPPLY THE CALIBRATION FORMULA.

Regarding the recalibration of the wireless tiltmeter, Worldsensing recommends recalibrations only for the following situations:

- When a tiltmeter certificate is required according to the quality program of the company/project. In this case, the certificate may be obtained locally. If a laboratory with a proper rotary frame is locally accessible, the wireless tiltmeter may be placed on the calibration frame to take measurements at different inclination steps. Then, if the probe is

found to be within the specifications, the laboratory will be able to print out a certificate for the wireless tiltmeter. Gain and Offset parameters will not be recalculated in this case. However, if the wireless tiltmeter is found to be out of tolerance, it will be necessary to send the device to Worldsensing.

- The tiltmeter requires repair. After repairing the device, it must be recalibrated. See the Troubleshooting section for more details.
- After completing a monitoring project. Civil works and mines are hard environments. During the project, the wireless tiltmeter can be affected by impacts, different levels of vibration, physical stresses and so on. Depending on the state of the wireless tiltmeter after project completion, you may need to return the tiltmeter to Worldsensing for inspection of the mechanical parts, reassembly and recalibration.

In case recalibration is needed, Worldsensing provides a calibration service. Please contact support@worldsensing.com for more information.

For the calibration process, Worldsensing will disassemble the wireless tiltmeter to inspect the mechanical parts before recalibrating the device.

13. Device and data management through CMT Edge

Once the device has been configured and the communication has been established with the GW, the user will be able to configure the different operational modes available for the tiltmeter G7: Triggered Measurements Mode and Event Detection Mode.

Triggered Measurements Mode configuration is addressed on a specific [document](#), while Event Detection Mode is addressed on chapter 15 of this user guide.

In this chapter, we focus on detailing Nodes panel information and files, including configuration of the engineering units.

From CMT firmware version 2.11 it is possible to use the tiltmeters connected in Legacy or in Worldsensing format. Please check the [CMT User guide](#) for more information and their implications and also Format chapter from this document.

If the tiltmeter has been configured successfully, the node's unique ID will become visible on the CMT Edge main page, enabling streamlined identification and management.

Signal coverage test map

Nodes

Id, name, serial or model

All 0 nodes selected of 25

Id	Name	Model	Status	Reporting period	Configuration
<input type="checkbox"/> 173269		LSG7VW-6XL0	Online	50m	
<input type="checkbox"/> 173305		LSG7VW-2XL0	Online	50m	
<input type="checkbox"/> 173314		LSG7VW-2XL0	Online		
<input type="checkbox"/> 175832		LSG7ACL-BXLH-TIL	Online	50m	
<input type="checkbox"/> 176822		LSG7ACL-BILR-VIB	Online		

« 1 2 »

Figure 9. CMT Edge Network view

Please check the [CMT user guide](#) for detailed information about the main panel and also the general features available through it.

Data files:

Different files will be available for tiltmeter LSG7ACL-BXLH-TIL:

- **Tiltmeter data (legacy) csv:** contains the information from X, Y and Z axis in degree amongst X, Y, and Z standard deviation in g, temperature and engineering data conversion (if it has been previously configured). This file will be available if legacy format has been configured from Configuration < General.
- **Reading error csv:** contains the error code and description.
- **Health file:** contains temperature, battery voltage, uptime in seconds, Relative humidity, standard deviation for Relative humidity and delta Relative humidity.
- **Tiltmeter data (Worldsensing Format) csv:** contains the information from X, Y and Z axis in degree amongst X, Y, and Z standard deviation in g, temperature and engineering data conversion (if it has been previously configured). This file will be available if legacy format has been configured from Configuration < General.
- **Statistics files**
 - **LSG7ACL-BXLH-TIL TMP stats CSV files:** this file contains the periodic statistical parameters according to the operational settings configured on the triggered mode.
 - **LSG7ACL-BXLH-TIL TMT stats CSV files:** this file contains the trigger statistical parameters according to the operational settings configured on the triggered mode.

Node 175832

[/ Networks / 21781 / Node 175832](#)

Name	
Installation date	
Comments	
Model	LSG7ACL-BXLH-TIL
Firmware version	3.13
Serial number	175832
Health CSV files	175832-health-current.csv + More
Errors CSV files	175832-reading-errors-2025-11.csv + More
Tiltmeter data (legacy) CSV files	175832-readings-current.csv + More
LSG7ACL-BXLH-TIL health CSV files	175832-LSG7ACLBXLHTIL-1-health-current.csv
LSG7ACL-BXLH-TIL TMP stats CSV files	175832-LSG7ACLBXLHTIL-1-stats-TMP-current.csv

[Last readings and Time series graphs](#)

Figure 10. CMT Edge Node view

In the same panel, below the CSV files, there are four tabs informing about the: Last readings and Time series graphs (1), Status (2), Metadata (will always remain blank) and Last Messages (3).

Last readings and Time series graphs:

Last readings and time series graphs are showing the last message from all the datapoints.

This information includes the latest health and reading parameters.

Also, statistical parameters from the last readings will be displayed.

On the right bottom from the panel, last messages type and time reception (in UTC) will also be displayed

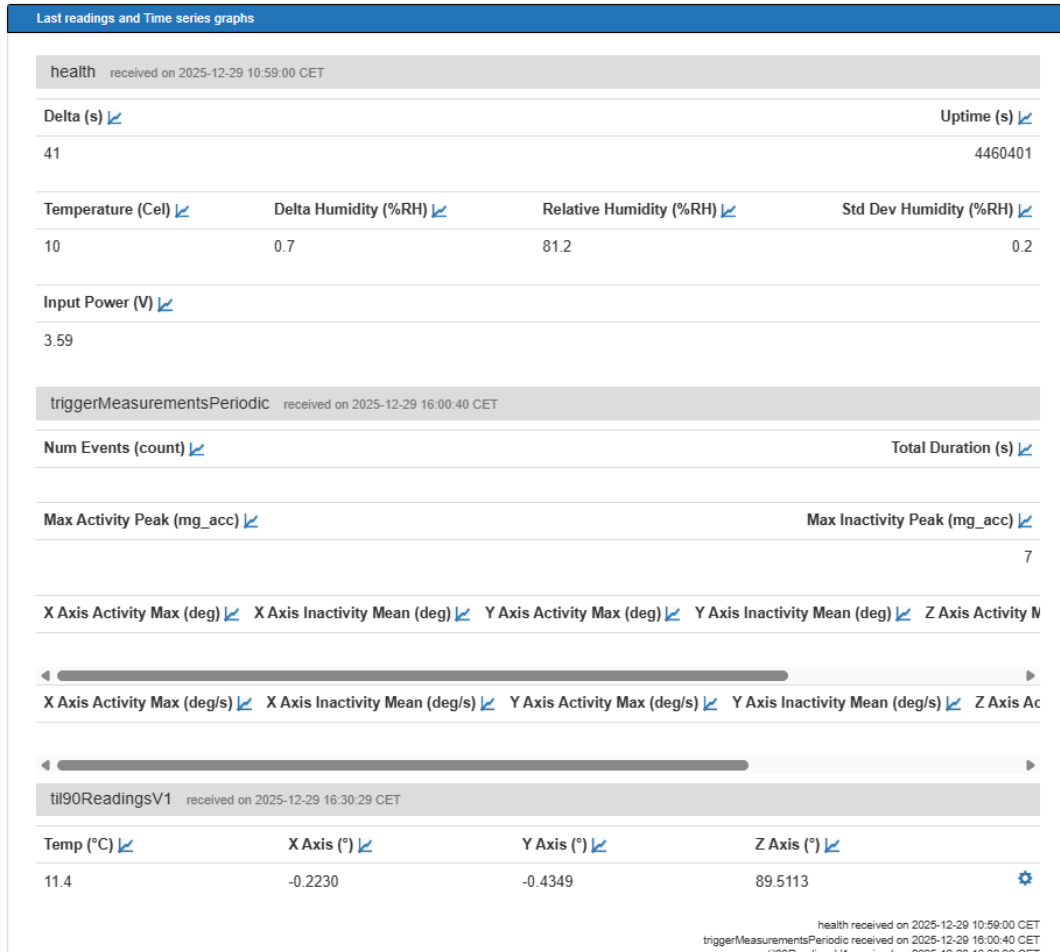

Figure 11. Example of Last Readings and Time series graphs tab.

On the right wheel the user will be able to configure the engineering units. If **Legacy format** has been selected, the user will see the formula available for conversion.

Engineering units

/ Networks / 21781 / Node 175832 / Engineering units

Channel 1

Use engineering units

Formula:

Angle variation (°)

Angle variation (°)

Custom units (sinus formula)

Custom units (tangent formula)

Figure 12. CMT Edge Engineering units menu.

- Angle variation

$$\Delta X = X_i - X_0$$

$$\Delta Y = Y_i - Y_0$$

$$\Delta Z = Z_i - Z_0$$

ΔX : Angle variation in degrees
 ΔY : Angle variation in degrees
 ΔZ : Angle variation in degrees
 X_i : Current angle reading in degrees
 Y_i : Current angle reading in degrees
 Z_i : Current angle reading in degrees

Where:

AX: angle variation in degrees

AY: angle variation in degrees

AZ: angle variation in degrees

X_i : Current angle reading in degrees

Y_i : Current angle reading in degrees

Z_i : Current angle reading in degrees

- Tangent generic equation (necessary to adjust it for the three axis)

$$E_x = C_x \tan(X_i - X_0) + D_x$$

$$E_y = C_y \tan(Y_i - Y_0) + D_y$$

$$E_z = C_z \tan(Z_i - Z_0) + D_z$$

E_x : Converted data in units.
 E_y : Converted data in units.
 E_z : Converted data in units.
 X_i : Current angle reading in degrees.
 Y_i : Current angle reading in degrees.
 Z_i : Current angle reading in degrees.

Where:

E_x, y, z : converted data in units

C_x, y, z : Multiplicative factor

D_x, y, z : Offset in units

X, Y, Z_0 : Zero reading

X, Y, Z_i : Current reading

- Sine generic equation (It is necessary to adjust it for the three axis)

$$E_x = C_x \sin(X_i - X_0) + D_x$$

$$E_y = C_y \sin(Y_i - Y_0) + D_y$$

$$E_z = C_z \sin(Z_i - Z_0) + D_z$$

E_x : Converted data in units.
 E_y : Converted data in units.
 E_z : Converted data in units.
 X_i : Current angle reading in degrees.
 Y_i : Current angle reading in degrees.
 Z_i : Current angle reading in degrees.

Where:

E_x, y, z : converted data in units

C_x, y, z : Multiplicative factor

D_x, y, z : Offset in units

X, Y, Z_0 : Zero reading

X, Y, Z_i : Current reading

Figure 13: Different formulae applicable for the angle conversion

If **Worldsensing** format has been selected, the user will be able to access axis by axis and configure engineering units

til90 received on 2025-12-23 16:41:04 CET					
X Axis (deg)	X Axis Std (deg)	Y Axis (deg)	Y Axis Std (deg)	Z Axis (deg)	Z Axis Std (deg)
-0.6158	6.25E-05	0.1642	6.25E-05	89.3627	3.125E-05
Temperature (Cel)					
24.5					

health received on 2025-12-23 16:10:27 CET
til90 received on 2025-12-23 16:41:04 CET

Figure 14: Configuration of engineering units for Worldsensing format

For each axis different formulae will be available. The user will be able to add the index of the formula in order to create the JSON source and the csv order, but also add a Name of the formula.

X Axis

Use engineering units

Formula:

Angle variation (°)

Enable the formula Angle variation (°)

$$\Delta Axis = Axis_t - Axis_0$$

ΔAxis: Angle variation in degrees
Axis: Current angle reading in degrees

Index of the formula. This index is used to create json source and to order the csv.

0

Name of the formula:

xAxisVariation

X₀: Initial angle in degrees:

Save

Figure 15: Configuration of engineering units for Worldsensing format. Index and Name

Status

It displays the same information about the radio transmissions as in other Loadsensing devices (see the CMT Edge guide).

Last messages

This tab includes the last received JSON formatted messages for each available kind. See Annex for data JSON formatted messages information.

13.1. Errors implemented

When an error is returned a new timestamp is registered on the reading error CSV file on the Gateway, the reading file will show blank readings corresponding to that timestamp.

There are several errors that can be returned on the CSV file, related to the tiltmeter sensor or the laser distance meter. On the table below there is a relation between the codes and the error description:

Type	Code	Description
General	1	Sensor does not respond
Specific	2	Sensor self test error.
	3	Sensor temperature bad reading.

While this feature is available for Legacy format, in WF mode the errors.csv is not generated as of CMT Edge 2.11.1. This functionality will be implemented in future versions

14. Device and data management through CMT Cloud

This section does not cover traditional configurations that can be carried out from the Cloud platform, such as changing the reporting period or assigning names and position to the node, among others. These aspects are covered in detail in the Cloud [user guide](#).

Only the distinctive features of the TILG7 node will be reviewed, without going into the configuration of Triggered Measurements Mode as it is addressed on a specific [document](#), while Event Detection Mode is addressed on chapter 15 of this user guide.

By selecting the node on **devices group management**, the user will be able to check the general details from it as model, status, reporting period, last message received, uptime in seconds but also the specific settings that have been applied according to the operational modes available.

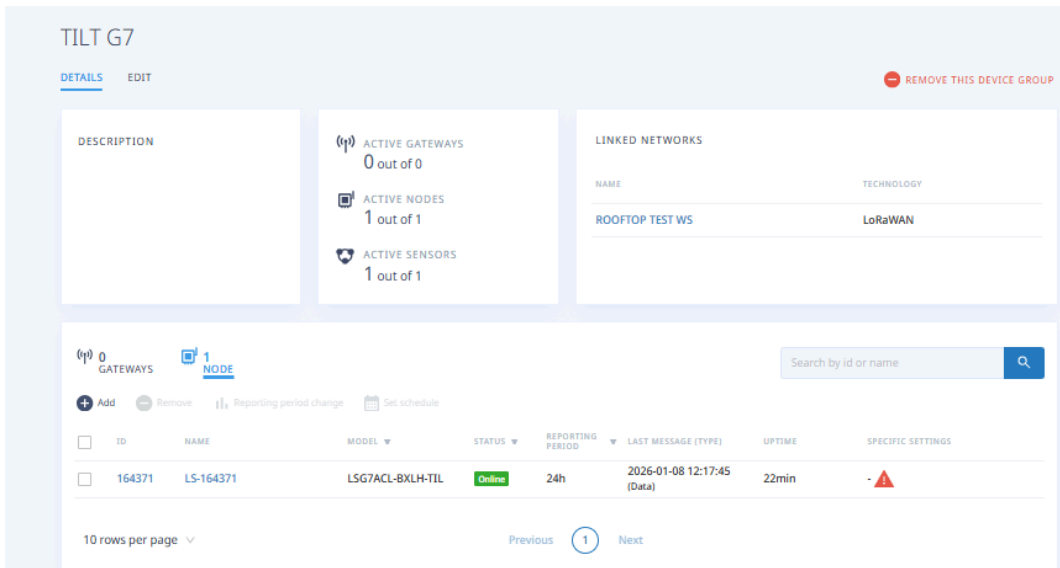

Figure 16: Device group management CMT Cloud

By selecting the node, the user will access to the Data Management panel. Engineering units can be configured through it by clicking “View all”.



Figure 17: Engineering units configuration

Different formulae are available on the drop down menu (sinus and tangent equation for converting into mm/m and angle variation).

The user will need to create, add a Name and an Index and select the formula to apply



New Engineering Unit

*Required fields

NAME *

Please fill in this field

INDEX

FORMULA *

- Change units (tangent formula)
- Angle Variation (degrees)
- Change units (sinus formula)

+ Add another formula - Remove selected formula

FORMULAS OF THIS ENGINEERING UNIT

New Formula

ENABLE ENGINEERING UNIT

Figure 18: Engineering units configuration on CMT Cloud. Formula selection

New Engineering Unit

*Required fields

NAME *

mm/m conversion

INDEX ●

1

FORMULA *

Change units (tangent formula) ▾

$$p_1 \tan(i_1 - p_2) + p_3$$

Allows to modify the value basing on cos formula, coefficient, and offset

i If the current formula assumes using another one as an input, then you first need to create it on the right.

I₁CURRENT ANGLE READING IN DEGREES *

axis_x ▾

P₁MULTIPLICATIVE FACTOR *

1

P₂OFFSET IN DEGREES *

0

P₃OFFSET IN OUTPUT UNITS *

0

OUTPUT UNITS

raw

RESULT NAME *

change_units_tangent_formula

+ Add another formula

− Remove selected formula

FORMULAS OF THIS ENGINEERING UNIT

change_units_tangent_formula

ENABLE ENGINEERING UNIT



Cancel

Create

Figure 19: Engineering units configuration on CMT Cloud.

15. Event Detection Mode

15.1 Overview

The Event Detection Mode (EDM) is a specialized operating mode designed exclusively for the LSG7ACL-BXLH-TIL and LSG7ACL-BILR-TIL. This mode enables the sensor to detect predefined abnormal movements and transmit alerts with very low latency, while maintaining low power consumption and long battery life.

Event Detection Mode is based on a data-by-exception approach. Instead of continuously transmitting all acquired measurements, the sensor locally evaluates data in real time and transmits information only when relevant conditions are met, such as when predefined thresholds are exceeded. This significantly reduces radio traffic and energy consumption while ensuring that critical events are reported immediately.

To operate correctly, the Event Detection Mode requires the use of the **MQTT communication protocol** enabling low-latency alert transmission and efficient integration with monitoring platforms.

While using an MQTT connector is recommended, Modbus TCP can also be used to exchange event and status information with local controllers or industrial systems for the CMT Edge architecture.

The EDM is intended to be used as a sensing component within early warning and monitoring systems. It can be integrated with third-party software platforms that support MQTT or Modbus TCP and are capable of processing alert notifications and triggering automated or manual actions, such as issuing warnings, activating alarms, or controlling external devices.

Despite relying on battery-powered sensors, the system achieves a battery lifetime of more than two years and supports long-range radio communication.

The Event Detection Mode is well suited for monitoring scenarios where rapid movement detection is critical. It is commonly applied in geotechnical monitoring, structural safety, and construction activities, where threshold-based alerts enable preventive or corrective actions.

Typical use cases include slope stability monitoring, embankment integrity assessment, detection of landslides or rockfalls, and monitoring of structures during complex construction operations such as load transfer, lifting, or incremental launching. In all cases, the combination of early

warning alerts with trend-based monitoring provides both immediate protection and long-term insight.

15.2. Operating Principle

When operating in Event Detection Mode, the tiltmeter sensor continuously samples data at a high sampling rate of 3.9 Hz. All measurements are processed locally within the sensor and the acquired data is not transmitted immediately; instead, each axis value is evaluated against the configured threshold to determine whether an event of interest has occurred.

The fundamental operating concept of EDM is the distinction between normal operation and alert operation. During normal operation, the sensor remains in a low-communication state and only transmits periodic status readings at a configurable interval. These periodic readings are intended to provide baseline information and long-term trends, rather than real-time data.

An event is defined as the moment when one or more monitored parameters exceed their configured limits. When such a condition is detected, the sensor immediately transmits a **real-time alert message** and transitions to an alert state. This message is generated as soon as the triggering measurement is detected and is intended to notify external systems with minimal delay.

In addition to the real-time alert message, the sensor also transmits a subsequent readings message containing the exact measurement values that caused the state transition. This message includes the relevant inclination data and allows downstream systems to analyze the event in detail. Unlike the alert message, this readings message is not time-critical and is transmitted after the alert has been issued.

When the sensor enters the alert state, it switches to a different and predefined reporting period, usually by increasing the frequency of measurements to allow closer monitoring of the detected movement. Once the monitored parameters return below the limits and remain stable for a predefined period, the sensor automatically leaves the alert state and returns to normal operation.

This operating principle enables the EDM to provide fast reaction to critical movements while maintaining efficient use of network capacity and sensor power, making it suitable for both early warning system scenarios and demanding construction or monitoring activities that require near real-time awareness of structural or ground movements.

The Event Detection Mode defines two primary operating states for the tiltmeter sensor: **a normal state and an alert state**. Each state is characterized by a distinct reporting behavior and is intended to balance monitoring requirements with communication efficiency.

- In the **normal state**, the sensor performs continuous internal sampling but transmits readings only at the configurable periodic interval. This reporting interval can range from 30 seconds to up to 24 h, depending on the size of the wireless network and the monitoring objectives. Each periodic transmission represents a baseline reading derived from a short measurement window, during which multiple samples are collected and statistically processed. Along with the inclination values, a standard deviation metric is included to provide an indication of signal stability and measurement noise.
- When an event is detected and the sensor transitions to the **alert state**, the reporting behavior changes. In this state, the sensor transmits readings more frequently, according to a reporting period predefined for alert conditions. This increased reporting frequency allows closer observation of the movement evolution while the system remains in a potentially critical situation. Once the monitored parameters return to acceptable conditions and remain stable for a predefined duration, the sensor automatically reverts to the normal state and resumes its original reporting behavior.

Event detection in EDM is based on a locally executed algorithm that continuously evaluates inclination measurements against predefined acceptance limits. The algorithm is designed to operate independently on each measurement axis and to respond immediately to abnormal behavior.

The primary detection method is the absolute threshold algorithm, which defines an upper and a lower limit for each enabled axis. These limits establish the acceptable angular range of operation. Any single measurement sample that exceeds this range on any axis is considered an event and immediately triggers the alert mechanism.

Thresholds can be configured individually for each axis within a defined angular range and with fine resolution. Event detection must be explicitly enabled per axis, allowing the monitoring configuration to be adapted to the expected deformation mechanisms of the structure or ground being observed.

To avoid oscillation between states and to ensure that alert conditions are genuinely resolved, the system does not immediately return to the normal state once the measured values re-enter the acceptable range. Instead, the sensor requires a continuous sequence of samples within the configured limits over a defined time window before clearing the alert state. This approach provides robustness against transient noise and short-lived disturbances.

When configuring thresholds, careful consideration must be given to environmental factors such as measurement noise and temperature effects, as overly tight limits may lead to excessive or false detections.

15.3. Event detection Alert and data reporting Messages

This section details what messages are sent through the EDM and how the datasever is managing them. Figure 12 shows a simplified system operation example. In the sake of clearness, only one axis and only one threshold have been considered in the figure.

Note: When the three axis are in EDM, thresholds may be sequentially broken and recovered during the alert state and, always that at least one axis is outside the thresholds, the alert state will remain and the system will collect readings in all the axis on the reporting period associated to the alert state. Only when all the axis are within the thresholds during at least the stoppage time, the system will return to the normal state mode.

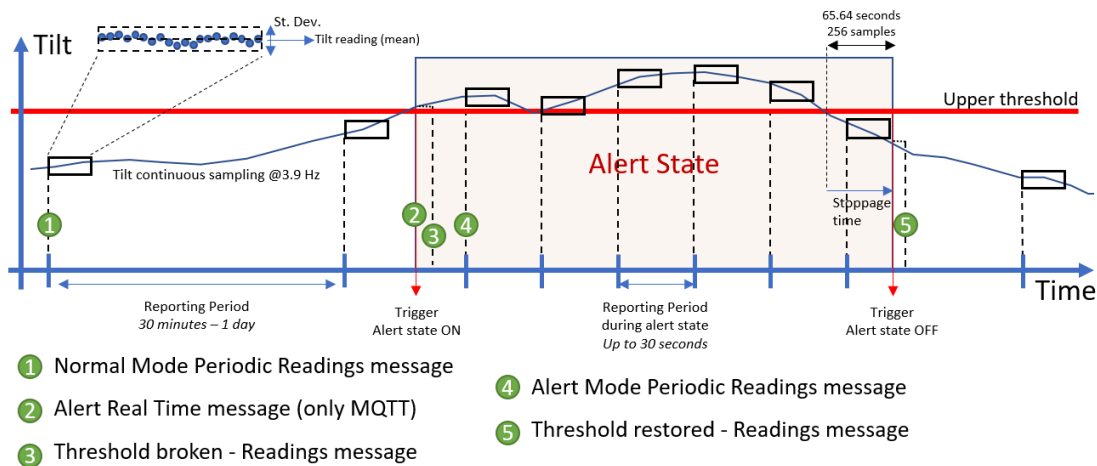

Figure 20: EDS simplified operation example. In green, are indicated the different messages transmitted.

In the prior figure we can identify up to five different messages, in three groups:

Periodic reading message: ①④

Reading messages including data acquired according to a selected periodicity. This group of messages include:

- 1) Normal State Periodic Readings: Acquired according to the configured periodicity when the alert state is off.
- 4) Alert State Periodic Readings: Acquired according to the configured periodicity during the alert state.

The tilt reading is computed averaging several samples of tilt, as done in the regular TIL90 devices, and therefore includes a standard deviation (shown in the graphic as a black rectangle). This is a reading message and the fields include the TIL90 regular fields and adds several fields with information about the status of the alert state and classifying it as a periodic reading (see the table for reading message below).

Alert state trigger message: ②

This kind of message is marked as 2) in the plot. This is a near real-time message generated whenever the continuous sampling exceeds any threshold in any axis and contains information about the alert state activation. Typical information about radio signals including frequency, RSSI, SNR and SF is transferred as well. As it is transmitted in near real time, the transmission timestamp is considered the trigger timestamp.

In this message there is information about the specific threshold involved but does not include information about the specific data which triggered the system. Only the angular amount exceeding the absolute threshold value is reported. This value is always positive and must be related to the specific broken threshold (upper/lower) and its direction of exceedance (addition/subtraction, respectively). The value resolution presents one integer significant digit (ranging from 1 to 9) followed by two significant digits for the decimal positions, which can only take 33 multiples values {00; 33; 67}. The exponents range from -2 (centi degrees) to 2 (hundreds of degrees). Differences are truncated to the closest lower value. This value is reported as a decimal number. The following table presents some examples of potential actual exceedances (only for illustrative purposes) and the related truncated and reported ones:

Exceedance		
Actual	Truncated	Reported
0.008	0.67E-2	0.00677
0.015	1.33E-2	0.01333
0.230	2.00E-1	0.2
3.456	3.33E0	3.3333
46.241	4.33E1	43.33333
104.315	1.00E2	100.0

This message will be sent only through MQTT and will not be accessible through the dataserer or the CSV file. For more details about this file format, please refer to the Appendix A.2.

Triggered Reading: 3 5

These are readings messages which are not periodically generated but triggered by one condition. Two kinds of messages are generated depending on the triggering condition:

- Whenever a first or any subsequent threshold is crossed, the system will generate a reading message, timestamped exactly at the time when the threshold was broken, including the data which triggered the message and its timestamp.
- When the continuous sampling returns in between the lower and upper threshold and remains there after a stoppage time (256 samples / 65.64 seconds) a message will be generated including the data of the last sample and its timestamp. This message indicates that the normal state has been reached again.

These messages are not generated instantly when the trigger is activated, but following the typical transmission cycle of the network, and for that they will not be considered real-time. The format of these messages is the same as the periodic readings, but includes several differences:

- The field `AlertTriggeredMsg-{ID}` will be 1 indicating this is a triggered message.
- The timestamp of this message will not be based on a periodic basis.

- The data transmitted will be the exact sample which generated the trigger, so no average is performed and standard deviation will be 0.
- Additional information about the thresholds will be provided for the messages 3).

All the readings messages will be transmitted and processed by the dataserver, as well as pushed through MQTT. On the other hand, alert messages will be only transmitted by MQTT.

For this reason, the CSV readings file downloadable from the CMT dataserver will only include the readings. From there, alert state activation and deactivation can be seen through the triggered readings, but take into account that these messages are not received in real-time and are not intended for integration in early warning tools.

Details on the CSV and JSON (pushed by MQTT) messages format can be found in the Appendix A.

Example

In this example, we show data from 2021-11-14, and we can interpret the device status following the lines of data and referring to the previous graph and numbers:

Date-and-time	Timezone	Tiltmeter-xAxis-deg	Tiltmeter-xAxisStd-deg	Tiltmeter-yAxis-deg	Tiltmeter-yAxisStd-deg	Tiltmeter-zAxis-deg	Tiltmeter-zAxisStd-deg	Thermometer-temperature-Cel
12/01/2026 16:00:00	UTC+01:00	-0,244	2,34E-05	-0,3867	2,34E-05	89,5428	2,34E-05	23,4
12/01/2026 16:02:00	UTC+01:00	-0,247	0,000390625	-0,3919	0,000304688	89,5368	2,73E-05	23,5
12/01/2026 16:04:00	UTC+01:00	-0,3388	1,95E-05	-0,4191	2,34E-05	89,4611	1,95E-05	23,5
14/01/2026 17:38:00	UTC+01:00	-0,9252	2,73E-05	-9,1963	3,13E-05	80,7564	2,34E-05	24,4
14/01/2026 17:40:00	UTC+01:00	-0,9258	1,95E-05	-9,1929	1,95E-05	80,7598	2,73E-05	24,4
14/01/2026 17:40:06	UTC+01:00	-0,9922	0	-10,9397	0	79,0142	0	24,4
14/01/2026 17:40:30	UTC+01:00	-0,9808	2,73E-05	-11,9284	2,73E-05	78,0301	2,73E-05	24,4
14/01/2026 17:41:00	UTC+01:00	-0,9795	3,52E-05	-11,9233	2,73E-05	78,0353	2,34E-05	24,4
14/01/2026 17:41:30	UTC+01:00	-0,9791	2,34E-05	-11,9219	3,52E-05	78,0368	1,95E-05	24,4
14/01/2026 17:42:00	UTC+01:00	-0,9778	3,13E-05	-11,9205	3,13E-05	78,0383	2,34E-05	24,4
14/01/2026 17:42:30	UTC+01:00	-0,9787	2,34E-05	-11,921	1,95E-05	78,0377	1,95E-05	24,4
14/01/2026 17:43:00	UTC+01:00	-0,9789	2,73E-05	-11,9214	1,95E-05	78,0373	3,13E-05	24,4
14/01/2026 17:43:30	UTC+01:00	-0,9768	1,56E-05	-11,9177	1,56E-05	78,0412	1,56E-05	24,4
14/01/2026 17:44:00	UTC+01:00	-0,9796	2,73E-05	-11,9194	3,13E-05	78,0392	2,34E-05	24,4
14/01/2026 17:44:30	UTC+01:00	-0,9789	3,52E-05	-11,9197	3,52E-05	78,039	2,34E-05	24,4
14/01/2026 17:45:00	UTC+01:00	-0,9807	1,95E-05	-11,9218	2,73E-05	78,0367	1,95E-05	24,4
14/01/2026 17:45:30	UTC+01:00	-0,8072	4,30E-05	-0,4128	3,13E-05	89,0934	2,73E-05	24,4
14/01/2026 17:46:00	UTC+01:00	-0,8051	2,34E-05	-0,4125	2,73E-05	89,0953	2,73E-05	24,4
14/01/2026 17:46:26	UTC+01:00	-0,8077	0	-0,4114	0	89,0934	0	24,4
14/01/2026 17:48:00	UTC+01:00	-0,8055	3,13E-05	-0,4121	1,95E-05	89,0952	1,95E-05	24,4

Figure 21: Message reception during the Thresholds activation.

- Tiltmeter is in a normal state, periodically reporting every 2 minutes. Readings are received accordingly (pale green). ①
- At 15:40:00, the device has been rotated and the alert state is declared (Thresholds were set to +10/-10 ° for XAxis and YAxis and in this case YAxis threshold has been broken). At this point, the device has entered the alert state, and a real-time alert message has been sent through MQTT at the exact timestamp of the occurrence.
- A triggered reading (orange highlighted message) has been sent at 14/01/2026 17:40:06 . The obtained tilt values can be compared with the threshold values. As a single sample is used in these triggered messages, the standard deviation is 0. ③

- After that, we can see a periodic readings with the reporting period associated with the alert state (30 seconds) for all the axis, having or not broken threshold (pale orange message). ④
- At some point between 17:45:00 and 17:45:30, the device is returned to its original position (all the values inside the thresholds). Nevertheless, the alert state keeps activated until the stoppage time is reached with all the axis without a broken threshold and periodic readings at 30 seconds are collected until the normal state is declared (soft orange highlighted readings).
- No alert messages are sent through MQTT at this point.
- When the normal state is active again, a reading triggered message is sent with the exact timestamp when the stoppage time has finished 17:46:26 (green highlighted message). In this case, the triggered message presents Standard deviation of 0, as only one sample is used. ⑤
- After this, the system starts reporting based on the normal state reporting period (2 minutes). ①

15.4. Latency and System Performance

Event Detection Mode minimizes the delay between the physical occurrence of an event and the delivery of a corresponding notification to external systems. Under typical conditions, end-to-end latency is usually within a few seconds.

Total latency consists of two main components:

1. Detection and Radio Transmission Time

Detection time depends on the local sampling rate of each sensor, which is not synchronized across devices. The time between a physical event and its detection is therefore bounded by the inverse of the sampling frequency. Once detected, the alert message is transmitted immediately.

The **normal-state reporting period** can affect radio transmission. If an event occurs while a node is sending a periodic message, as the event must wait until the transmission completes, introducing additional latency.

The likelihood of added latency decreases as the reporting period increases:

- 30-second period: ~60% probability of added latency
- 5-minute period: 94% of events meet expected latency, 6% overlap probability

- 30-minute period: 99% of events meet expected latency, 1% overlap probability



Recommendation

Configure a normal-state reporting period of **30 minutes or longer** (e.g., 1–2 hours) to keep added latency close to or below 1%.

2. Software Processing Time

This includes message handling at the gateway and forwarding via the selected communication protocol. Latency depends on system architecture and the number of devices reporting events simultaneously. Cloud-based architectures generally scale better, while edge-based deployments may experience slightly higher processing delays under heavy load.

Even when multiple sensors detect events simultaneously, the system maintains predictable performance. In most cases, alert messages are delivered within a few seconds, enabling timely decision-making and response.

Typical Latency Examples:

- First 5 wireless tiltmeters exceeding a threshold: MQTT message published in < **2 seconds** in >99% of cases
- First 25 wireless tiltmeters exceeding a threshold: MQTT message published in < **5 seconds** in >99% of cases

15.5. Transmission Reliability, Radio Network Characteristics and Coverage

High reliability of alert delivery is a fundamental requirement of the Event Detection Mode. To achieve this, several techniques are implemented at the radio communication level.

Each alert message is transmitted using a randomly selected channel from the available channel set, reducing the likelihood of collisions. After the initial transmission, multiple retransmissions are scheduled within a short time window to increase the probability that at least one copy of the message is successfully received by the gateway.

This combination of channel diversity and controlled retransmissions results in a very high probability of successful message delivery, even in scenarios where multiple sensors transmit alert messages simultaneously.

To maximize overall network capacity and ensure timely delivery of alert messages, the Event Detection Mode operates using a fixed spreading factor (SF 7) optimized for throughput. While this configuration reduces the maximum achievable radio range compared to other operating modes, it enables the system to support a higher number of simultaneous alert transmissions.

In Europe, where operation is typically possible from SF7 to SF11, using SF7 in EDM results in approximately **60% less coverage** compared to standard Loadsensing devices. In regions such as **Brazil and the USA (FCC)**, where operation is limited to SF7 to SF9, the coverage reduction is approximately **50%**.

The table below provides **indicative radio range estimates** for Brazil, North America, and Europe using a TIL90 operating in EDM:

RADIO RANGE	US 902-928MHz (FCC)	Brazil 915-928 MHz	EU 868 MHz
Open sight	7.5 km	7.5 km	6 km
City street	2 km	2 km	1.6 km
Manhole in a city street	1 km	1 km	0.8 km
Tunnel	2 km	2 km	1.6 km
Note: The distances have been tested by Worldsensing in real projects using standard antennas. However, the actual radio range depends on the environment, so these distances are only indicative values. Contact Worldsensing to discuss the details of your application.			
Bidirectional communications: Remote configuration changes/clock synchronization			
Sensitivity (SF7):	-127 dBm	-127 dBm	-127 dBm
Sensitivity:	-131 dBm (SF9)	-131 dBm (SF9)	-137 dBm (SF11)
Maximum link budget (SF7):	147 dB	147 dB	141 dB

15.6. Integration with External Systems

The Event Detection Mode is intended to be integrated with external software platforms responsible for processing alerts and executing response actions. Real-time alert messages are delivered using lightweight communication protocols suitable for automation and control systems.

MQTT is the primary protocol used for publishing alert notifications in a structured data format. This enables straightforward integration with third-party applications, which may generate notifications, activate alarms, or control external devices based on received events.

For edge-based deployments, an **MQTT license** must be enabled on the CMT Edge. This license is a paid feature and is not enabled by default. To activate it, customers must contact their Sales Area Manager, who will assist with the licensing and activation process.

Since EDS-mode tiltmeters can be a critical component of an Early Warning System (EWS), we recommend that the EWS management software also monitors gateway operational status. The JSON messaging documentation provides detailed information on the Gateway Keep-Alive messages available for both CMT Edge and CMT Cloud gateways.

Modbus TCP is also supported on CMT Edge, allowing integration with industrial control systems. Care must be taken when polling alert registers at high frequency to avoid unnecessary processing load on the gateway.

Other data delivery mechanisms, such as file-based transfers or REST-style API calls, are not used for alert notifications and are reserved for non-time-critical data.

15.7. Remote Configuration and Device Management

Once the G7 tiltmeter has been configured on the CMT, a lighting indicator and a gear icon will appear on the right side of the panel.

Standard Loadsensing parameters, such as the sampling rate in normal state (periodic reporting of readings), are configured from the main network page, in the same manner as for other Loadsensing nodes.

Network: Network 01 

/ Networks / 701

Comments Test

Compacted custom CSV [download compacted-custom-readings-701-Test_Custom_CSV-current.dat files](#)

 Signal coverage test map

Nodes

All 0 nodes selected of 11





























Id 	Name 	Model 	Status 	Reporting period 	Configuration
<input type="checkbox"/> 29802		LS-G6-DIG-2-FCC	Offline	 	
<input type="checkbox"/> 134705		LS-G6-VOLT-4-FCC	Offline		
<input type="checkbox"/> 136510		LS-G6-PICO	Offline		
<input type="checkbox"/> 144606		LS-G6-VOLT-4-FCC	Offline		
<input type="checkbox"/> 152625		LSG7ACL-BXLH-VIB	Offline		 
<input type="checkbox"/> 153965		LSG7GNS-SXLH	Offline		 
<input type="checkbox"/> 159950		LS-G6-TIL90-X	Offline		
<input type="checkbox"/> 162855		LSG7GNS-SXLH	Online		 
<input type="checkbox"/> 164371		LSG7ACL-BXLH-TIL	Online		  
<input type="checkbox"/> 170757		LSG7GNS-SXLH	Offline		 
<input type="checkbox"/> 170813		LSG7GNS-SXLH	Offline		 

Figure 22: Network visualization on CMT Edge

To configure the Event Detection Mode, the user must select the gear icon. Upon accessing this menu, the user will be able to define the reporting period in the alert state, enable or disable the Event Detection Mode, adjust threshold values, and apply offset values for each axis.

Visual indicators in the management interface provide contextual information about the current state of each device, including whether it is operating in normal or alert state.

Whenever a configuration change is applied to a node from the dataserver, a downlink message is sent from the gateway to the corresponding sensor. For the configuration update to take effect, this downlink message must be successfully received by the node.

 Signal coverage test map

Nodes

All 0 nodes selected of 11









Id 	Name 	Model 	Status 	Reporting period 	Configuration
<input type="checkbox"/> 164371		LSG7ACL-BXLH-TIL	Online		  

Figure 23: Changing node's configuration on CMT Edge

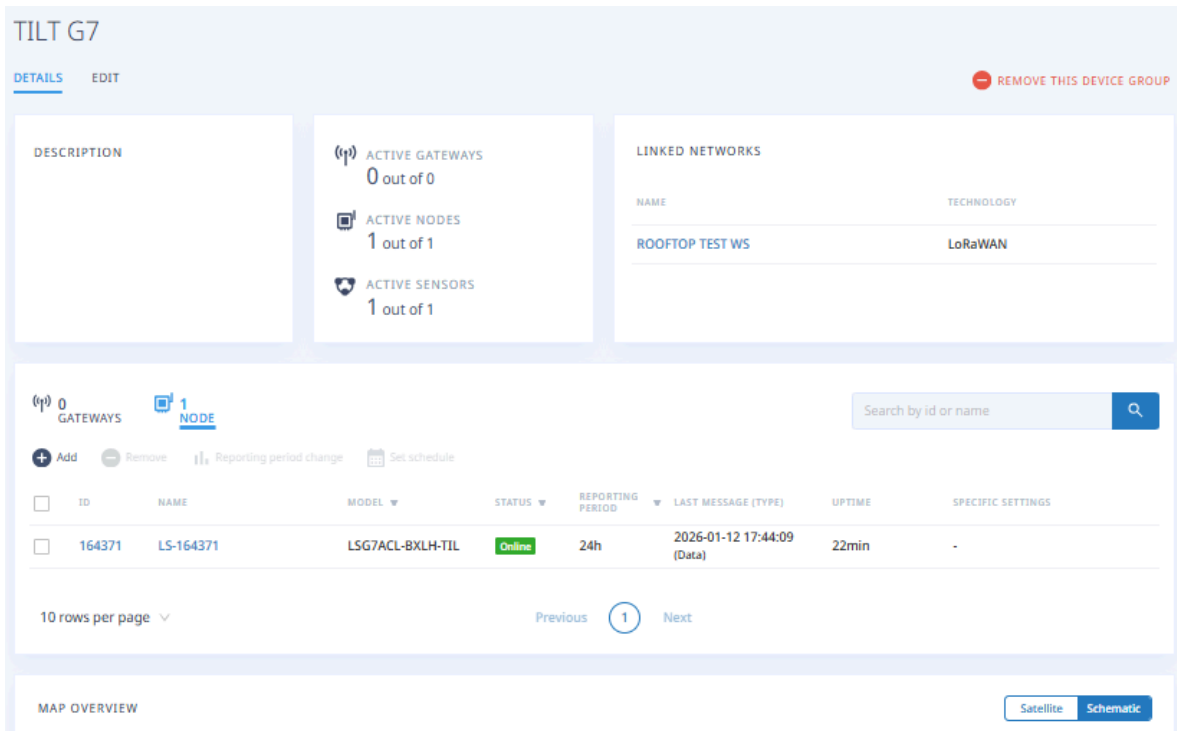

Figure 24: CMT Cloud visualization

15.7.1. Specific Configurable Parameters

Sampling Period in Alert State

This parameter defines the reporting period of readings while the node is in the alert state, corresponding to a denser reporting rate than in normal operation.

For monitoring consistency, it is recommended that the reporting period in the normal state be longer (i.e. less frequent) than the reporting period configured for the alert state.

Very short alert-state sampling rates can be configured; however, these high-frequency reporting configurations significantly increase the number of transmitted messages. Depending on the number of nodes simultaneously in the alert state, the gateway may be unable to assign appropriate transmission slots to all incoming messages. This can result in message loss. Users should be aware that, under such conditions, some alert-state readings may not be received.

Configuration

/ Networks / 701 / Node 164371 / Configuration

Event detection mode LSG7ACL-BXLH-TIL

Configure the event detection mode through the following form and changes will be applied remotely. It is also possible to introduce the absolute threshold or add/subtract an offset to the current reading in order to facilitate the configuration. Using the offset, the threshold will be defined from the last reading received on: 2026-01-12T09:34:00Z

WARNING: Be aware that enabling Event Detection will force the node's transmission to use a limited spreading factor (SF7). This may place it out of gateway range, preventing you from receiving the configuration change confirmation or any future messages.

Before proceeding, it is recommended to ensure that the node has a very strong radio link with the gateway — either by checking the signal of its latest messages (the SF should be 7) or by performing a coverage test.

Common configuration

Sampling period on alert state

1 minute

30 seconds

1 minute

2 minutes

5 minutes

10 minutes

15 minutes

30 minutes

1 hour

2 hours

4 hours

6 hours

12 hours

24 hours

Axis X configuration

Event detection mode

Axis Y configuration

Event detection mode

Axis Z configuration

Event detection mode

Disable

Save and apply

Side will break the limitations of reporting. Make sure to understand the documentation. Manage up to 30 data messages per message loss.

Figure 25: Configuration to Event Detection mode operation through CMT Edge. Sampling period on alert state.

TILT G7 / LS-164371

DETAILS EDIT CONFIGURATION LOGS REMOVE FROM DEVICE GROUP

GENERAL SETTINGS SPECIFIC SETTINGS

OPERATION MODE

Standard Event Detection

Periodic readings according to the configured reporting period.

OPERATIONAL SETTINGS

Triggered Acquisition Off Collect Baseline Readings Take Triggered Readings

Cancel Save

Figure 26: Configuration to Event Detection mode operation through CMT Cloud.

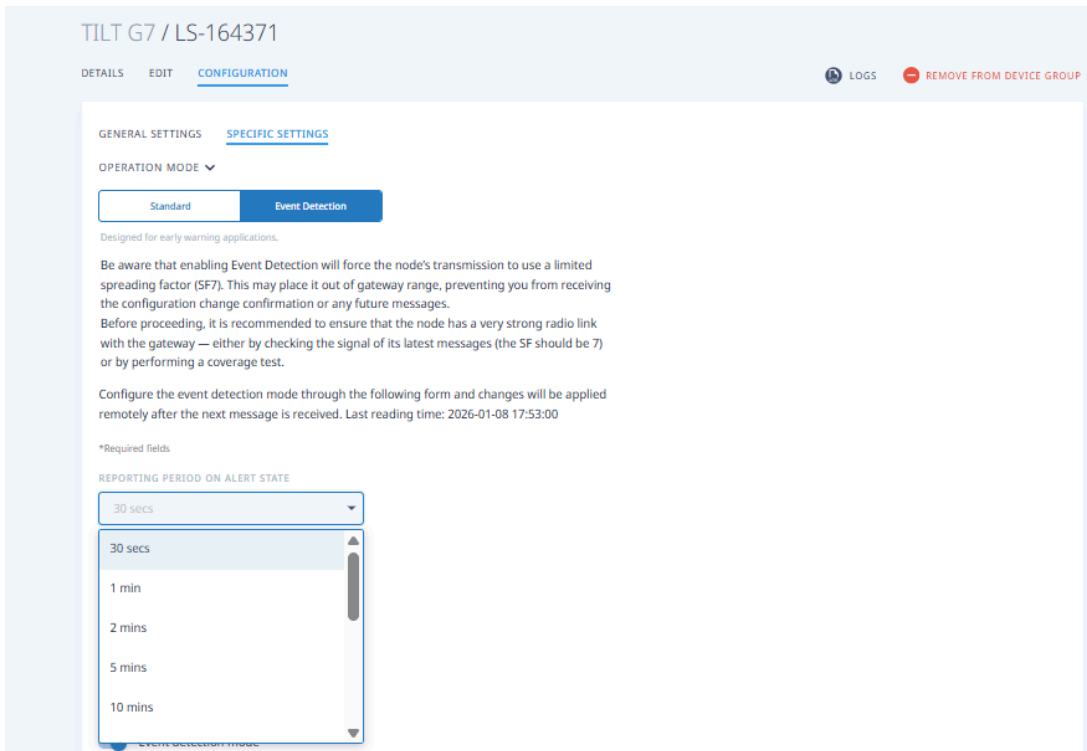

Figure 27: Configuration to Event Detection mode operation through CMT Cloud. Reporting period on alert State.

Axis Threshold Configuration

This section allows the configuration of upper and lower thresholds for each measurement axis (X, Y, and Z).

Each axis can be individually enabled or disabled. Thresholds can only be configured for axes that are enabled and actively measuring. If an axis is disabled, threshold configuration for that channel is not available.

For enabled axes, thresholds can be defined using one of the following methods:

Absolute Threshold Values

Thresholds can be entered manually by specifying absolute upper and lower limit values. The accepted range for these values is from -90.00° to $+90.00^\circ$, with a resolution of up to two decimal places. Both positive and negative values are allowed.

Thresholds Based on Deviation from the Current Reading

Alternatively, thresholds can be defined relative to the sensor's current measurement. The current reading is displayed in the configuration interface as a reference value. In this case, the user specifies a positive offset value (Δ°) in the Add/Subtract offset field, with up to two decimal places.

Based on the current reading (r) and the specified offset, the system automatically calculates and fills the absolute thresholds as follows:

- Absolute Upper Threshold = $r + \Delta^\circ$
- Absolute Lower Threshold = $r - \Delta^\circ$

The resulting threshold values are constrained to the valid range of -90.00° to $+90.00^\circ$. Any calculated values exceeding this range are automatically truncated to the nearest allowable limit. When thresholds are defined using this method, any previously entered absolute values are replaced.

Common configuration

Sampling period on alert state: 1 minute

Selecting a dishonored sampling the node will break the limitations of reporting period whenever the node is in alert state. Make sure to understand the implications exposed in the technical documentation. In standard conditions, this system can manage up to 30 data messages per minute. In case of overload, there could be message loss.

Axis X configuration

Event detection mode: Enabled

Absolute upper threshold (°): 10

Absolute lower threshold (°): -10

Reading: -0.3647

Add/Subtract offset (°): 0.00

Buttons: +, -, Apply offset

Axis Y configuration

Event detection mode: Enabled

Absolute upper threshold (°): 10

Absolute lower threshold (°): -10

Reading: -0.3803

Add/Subtract offset (°): 0.00

Buttons: +, -, Apply offset

Axis Z configuration

Event detection mode: Disabled

Buttons: Save and apply

Figure 28: Axes configuration for Event Detection mode operation through CMT Edge.

TILT G77 LS-104371

DETAILS EDIT **CONFIGURATION**

GENERAL SETTINGS **SPECIFIC SETTINGS**

OPERATION MODE ▾

Standard **Event Detection**

Designed for early warning applications.

Be aware that enabling Event Detection will force the node's transmission to use a limited spreading factor (SF7). This may place it out of gateway range, preventing you from receiving the configuration change confirmation or any future messages. Before proceeding, it is recommended to ensure that the node has a very strong radio link with the gateway — either by checking the signal of its latest messages (the SF should be 7) or by performing a coverage test.

Configure the event detection mode through the following form and changes will be applied remotely after the next message is received. Last reading time: 2026-01-12 17:44:00

*Required fields

REPORTING PERIOD ON ALERT STATE

30 secs ▾

NOTICE IS SENT TO

You can enter multiple email addresses separated by commas. Please use corporate emails.

AXIS X CONFIGURATION

Event detection mode

AXIS Y CONFIGURATION

Event detection mode

AXIS Z CONFIGURATION

Event detection mode

Cancel Save

AXIS X CONFIGURATION

Event detection mode

ABSOLUTE UPPER THRESHOLD (*) *

10

ABSOLUTE LOWER THRESHOLD (*) *

-10

ADD/SUBTRACT OFFSET (*)

The offset updates thresholds based on the last reading

READING

-0.9242

AXIS Y CONFIGURATION

Event detection mode

ABSOLUTE UPPER THRESHOLD (*) *

10

ABSOLUTE LOWER THRESHOLD (*) *

-10

ADD/SUBTRACT OFFSET (*)

The offset updates thresholds based on the last reading

READING

0.0027

AXIS Z CONFIGURATION

Event detection mode

Cancel Save

Figure 29: Axes configuration for Event Detection mode operation through CMT Cloud.

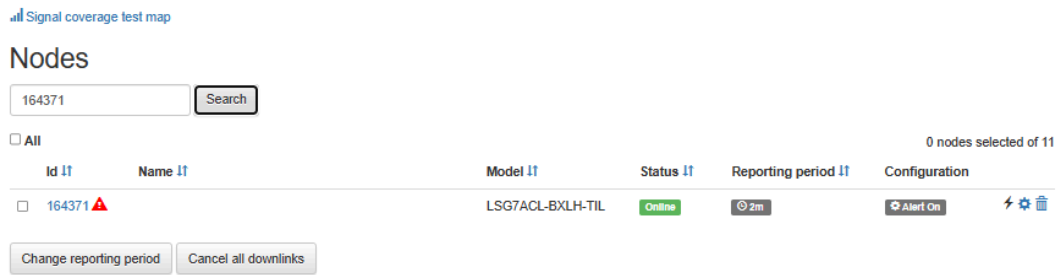

Figure 30: Alert state status on Event Detection mode operation through CMT Edge.

15.8 Requirements and Recommendations for Successful Deployment

Successful implementation of the Event Detection Mode requires careful planning and validation. Threshold values should be defined based on engineering analysis, testing, or numerical modeling to ensure meaningful detection without excessive false alerts.

It is important to understand that enabling Event Detection will force the node's transmission to use a limited spreading factor (SF7). This may place it out of gateway range, preventing you from receiving the configuration change confirmation or any future messages.

Integration with external systems must be verified in advance, including the definition and testing of response logic and escalation procedures. Infrastructure components such as gateways should be protected against power interruptions, and redundancy should be considered for critical installations.

Sensor placement should be carefully designed to cover all areas of potential movement, with additional redundancy in zones of higher risk. Ongoing maintenance, periodic testing, and clearly defined remedial actions are essential to ensure the long-term reliability and effectiveness of the monitoring system.



Important Note

Before enabling the EDM it is recommended to ensure that the node has a very strong radio link with the gateway, either by checking the signal of its latest messages (the SF should be 7) or by performing a coverage test.

If EDS-mode tiltmeters are integrated into an Early Warning System (EWS), a redundant gateway deployment is recommended. This ensures each tiltmeter can communicate with two gateways, providing system resilience in the event of a gateway failure.

16. Maintenance and troubleshooting

The node is packaged in a rugged aluminum box with a plastic lid and should provide many years of trouble-free operation.

Tilt-XHP/Tilt-IR require no maintenance other than normal cleaning, battery replacement and inspection of the seals. Apart from this maintenance, the devices are not field serviceable.

The Tilt-XHP/Tilt-IR is a precision instrument. Minor external actions or changes in the initial conditions of the structure, such as rust in the supports, construction pathology or thermal behavior, can cause changes in the tilt readings. Visual inspections can help to understand the cause of some registered movements.

It is important to avoid any impact to protect the internal sensors and to avoid distorting the mechanics of the device, as the reliability of the wireless tiltmeter reading can be affected by impacts, high vibration levels or Water ingress. The wireless node should never be submerged in water. **WATER DAMAGE TO INTERNAL COMPONENTS VOIDS THE WARRANTY.**

In case of doubt regarding the reliability of the readings, first inspect the wireless node mounting and the structure where it is attached. Any compromise to or mechanical deformation of the mounting hardware can cause unstable readings.

After ruling out issues related to the structure or the mounting hardware, we recommend installing the device on a known stable place and compare data. If the results of the wireless tiltmeter lead to think that the unit is not working as expected, please open a ticket to support@worldsensing.com in our Help Center to request a Return Material Authorization (RMA).

After receiving the device, Worldsensing will inspect the mechanical parts, reassemble and recalibrate the device. If this occurs after expiration of the warranty, Worldsensing will repair the equipment at its factory and may require additional charges for parts and labor charges. Worldsensing will provide a quote for repairs, if feasible, for products returned after warranty expiration.

Worldsensing is not liable for damages or erroneous decisions caused by defective units, since it is only responsible for the warranty of the equipment.

After finishing a project, we strongly recommend contacting Worldsensing to assess if the device requires any inspection or calibration service before being used in any other monitoring project.

17. Battery Life Estimates

In this chapter we are providing battery life estimations according to the different operational modes available on the node and considering different scenarios.

In the table below, battery life estimations are presented for the **periodic operational mode**. These results are based on tests conducted by SAFT using LSH20 Saft model and considering Typical Europe radio configuration (Spreading factor 9, radio transmit power 14dBm), Barcelona weather profile and average values have been used.

Battery Model		LSH20
Number of cells		1 cell
Reporting period	30 s	0.8 years
	5 min	5.8 years
	30 min	12.9 years
	1 h	14.7 years
	6 h	16.6 years

Table 2: Battery life estimation for periodic operational mode considering Spreading factor 9, radio transmit power 14dBm and using LSH20 Saft model batteries

Calculations have been also done by using Spreading factor 8, radio transmit power 20dBm.

Battery Model		LSH20
Number of cells		1 cell
Reporting period	30 s	0.6 years
	5 min	5.0 years
	30 min	12.2 years
	1 h	14.2 years
	6 h	16.4 years

Table 3 Battery life estimation for periodic operational mode considering Spreading factor 8, radio transmit power 20dBm and using LSH20 Saft model batteries

In the table below, battery life estimations are presented for the **Triggered mode** using absolute angle as triggered type and considering 1 event measurements per day and 1 periodic statistics report. These results are based on tests conducted by SAFT using LSH20 Saft model and considering Typical Europe radio configuration (Spreading factor 9, radio transmit power 14dBm), Barcelona weather profile and average values have been used.

Battery Model		LSH20
Number of cells		1 cell
Reporting period	30 s	NA
	5 min	5.7 years
	30 min	12.4 years
	1 h	14.0 years
	6 h	15.8 years

Table 4: Battery life estimation for triggered mode considering Spreading factor 9, radio transmit power 14dBm and using LSH20 Saft model batteries

In the table below, battery life estimations are presented for the **Event Detection mode** These results are based on tests conducted by SAFT using LSH20 Saft model and considering Spreading factor 7, radio transmit power 14dBm, Barcelona weather profile and average values have been used. In addition, it is worth mentioning that these estimations do not include any triggered alert.

Battery Model		LSH20
Number of cells		1 cell
Reporting period	30 s	NA
	5 min	2.4 years
	30 min	3.3 years
	1 h	3.5 years
	6 h	3.6 years

Table 5: Battery life estimation for Event detection mode considering Spreading factor 7, radio transmit power 14dBm and using LSH20 Saft model batteries

18. Data storage

Data storage periods are indicated in Table 6. Memory mode is a circular buffer. When the memory is full, logging continues by overwriting the earliest readings. Aside from the sensor readings, the device also collects health data hourly, which indicates the battery voltage, the internal temperature of the device and the device uptime.

Number of sensors	Sampling rate		
	60 minutes	30 minutes	10 minutes
1	49 years	26 years	9 years

Table 6: Data storage periods (without overwriting) for the wireless LSG7ACL-BXLH-TIL & LSG7ACL-BXLR-TIL on periodic mode.

For both the triggered and event-detection modes, storage capacity will decrease from the baseline depending on the number of readings taken in each mode. If additional information is needed, please request it through industrial@worldsensing.com.

Data is stored in comma-separated value (CSV) files. You can download readings and health files using WorldsensingApp.

To do this, connect an Android device to the data logger. When WSAApp loads, press "Download data". You need to set a start and end date for the data you want to download or alternatively you can enable "All data". The Android device allows these CSV files to be opened with applications such as e-mail or cloud apps. Files are also stored in the device memory, on the SD card in the WS App folder.

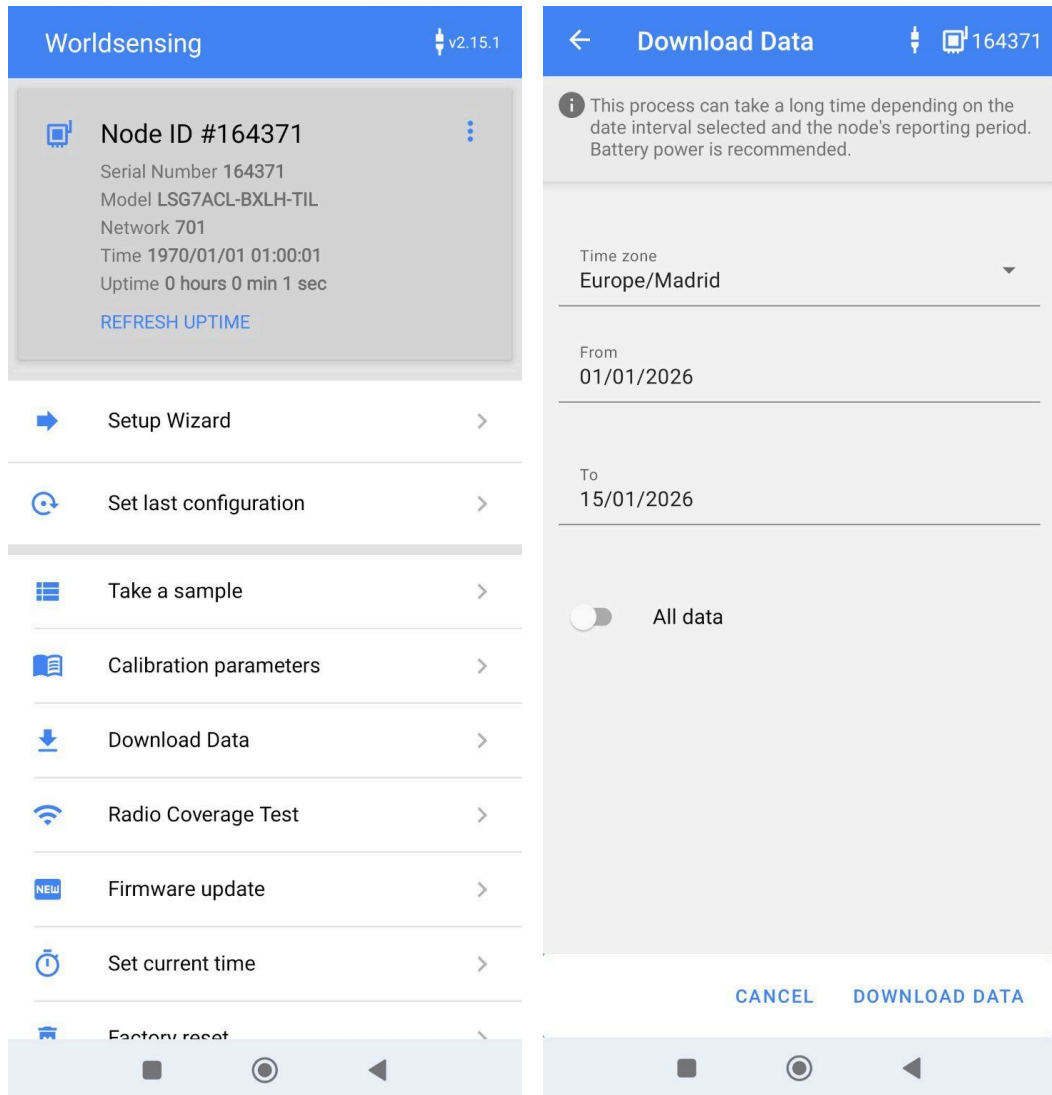

Figure 31: Downloading data manually from the wireless tiltmeter G7

19. Formats

On Loadsensing CMT Edge 2.11 firmware version, as well as CMT Cloud 2.13 version, a new format has been implemented for new Generation 7 edge devices. The purpose of it is unifying all messages in order to simplify the integration with other monitoring platforms.

This new format, named Worldsensing format is set by default for all Gen7 data loggers integration, while standard "Legacy" format remains for Gen6 data loggers.

When using CMT Edge, it is possible to select the desired format for tiltmeters, either Legacy or Worldsensing format, although this will determine the format of all tiltmeters connected to the same GW.

Attached is a guide showing the different formats available according to CMT Edge or Cloud, as well as the firmware version

Device	CMT Edge 2.10.1	CMT Edge 2.11	CMT Cloud 2.13
G6 Tiltmeter	LF	WF/LF	LF
G7 Tiltmeter	LF	WF/LF	WF

Table 8. Tiltmeter Compatibility according to different CMT versions, architecture and node generation

Legend: LF (Legacy Format), WF (Worldsensing Format)

Please refer to the [CMT user guide](#) for extended information.

20. FAQs

Do I need to apply temperature correction to the wireless tiltmeter?

The G7 tiltmeter sensor temperature dependency is up to $\pm 0.002^{\circ}\text{C}$ for the Tilt-XHP and $\pm 0.005^{\circ}\text{C}$ for the Tilt-IR, the same than for the G6 family.

To reduce thermal effects, we recommend installing the device indoors where possible in order to avoid sun exposure. If not, we suggest installing it in the shade, as sun exposure causes a thermal gradient on the enclosure.

Changes in temperature will cause structure and tiltmeter thermal effects. The best way to measure tilt is to determine the temperature behavior of the structure before activities start. Ideally, this baseline should be extended for a year to cover seasonal changes. With this baseline, it will be possible to distinguish temperature-induced movements (including those of the tiltmeter) from others.

Is the accuracy from the Tilt-XHP/Tilt-IR the same on all the ranges?

We have tested the accuracy within different positions ($\pm 4^{\circ}$, $\pm 15^{\circ}$, $\pm 45^{\circ}$, $\pm 86^{\circ}$). The results are shown on the specs (the biggest is the angle measured, the accuracy is reduced).

As the device can be installed on any position, we always recommend when possible to refer the measurements to the lowest angle measured to obtain higher accuracy.

We could say that as in most of the applications where the Tilt-XHP is used an angle below 4° is being measured, so the accuracy is $\pm 0.005^{\circ}$ and $\pm 0.006^{\circ}$ for the Tilt-IR.

Why is there a difference in the accuracy between both devices?

The main difference is due to the vibration resistance of the MEMS sensor for Tilt-IR. This device has been designed to work in environments with accelerations below $\pm 80g$, this is mainly due to the fact that this device has been designed for railway application, where vibration is an important point to be considered. This makes the specs from Tilt-IR lower than the Tilt-XHP.

Which are the main differences between LS-G6-TIL90-X/LS-G6-TIL90-I and Tilt-XHP/Tilt-IR?

In terms of hardware specs model LS-G6-TIL90-X is equivalent to Tilt-XHP, while model LS-G6-TIL90-I is equivalent to Tilt-IR as they are using the same MEMS.

Some improvement, has been done for Tilt-XHP/Tilt-IR, as they are including a more precise temperature and humidity sensor, that will allow having better internal temperature registers but also assessing the information if the node has been properly closed.

On the firmware side, the new devices will include different operation modes besides the normal one that will allow the nodes to operate according to exceptions.

Can I have G6 Edge devices coexisting with G7 Edge devices within the same Network?

On Loadsensing CMT Edge 2.11 firmware version, as well as CMT Cloud 2.13 version, a new format has been implemented for new Generation 7 edge devices. The purpose of it is unifying all messages in order to simplify the integration with other monitoring platforms.

This new format, named Worldsensing format is set by default for all Gen7 data loggers integration, while standard "Legacy" format remains for Gen6 data loggers.

It is possible to combine different Loadsensing devices from G6 and G7 generation within the same Network understanding that different formats will be created and new integrations may be needed to be done.

What happens if I have G6 tiltmeters coexisting with G7 tiltmeters within the same Network? Which format would be available?

It is important to understand that although it is possible to have G6 and G7 tiltmeters coexisting in the same Network, the user must decide whether the data is obtained in Legacy format or Worldsensing format through the General panel. For more information please check section 4.1 from the CMT USER GUIDE

21. Environmental best practices

To ensure responsible use, energy efficiency, and proper lifecycle management of Worldsensing devices, please follow the guidelines below:

Energy-Efficient Installation & Operation

- Install the device in an energy-efficient manner by minimizing power consumption.
- Set the reporting interval only as frequently as required by the monitoring project. Avoid overly frequent transmissions unless necessary for safety, regulatory compliance or to meet project requirements. This reduces battery usage, extends device lifespan, and minimizes environmental impact.
- Deactivate unused or unnecessary functions and services to reduce energy consumption.
- Regularly maintain the Edge devices to ensure accurate data collection.

Storage Between or After Projects

When a monitoring project is completed, remove the batteries and store the device in a:

- Safe, dry and temperature-stable environment (between 15°C and 25°C). Proper storage helps preserve electronic components and allows for future reuse.

Product End-of-Life (EoL) and Disposal

Take all necessary steps to extend the usable life of the product and reuse it in future projects where feasible. Once the product reaches end of life (EoL):

- Ensure batteries are removed from the equipment.
- Do not discard the product or batteries as unsorted municipal waste.
- Recycle all components in accordance with the European Union WEEE Directive 2012/19/EU.
- Deliver devices and batteries to authorized collection facilities for recovery and recycling.

Return Material Authorization (RMA)

In the event of requesting a Return Material Authorization (RMA) please make sure to use the most environmentally friendly mode of transportation possible. Ensure all items are properly packaged to prevent damage and reduce waste.

Product packaging

Worldsensing's product packaging is recyclable. Separate packaging materials (e.g., cardboard, plastic, foam) to ensure proper waste management in line with local regulations.

Safety and emergency procedures

- Read the safety sheet that comes with our products before installing them. For safety information on batteries and other materials, as well as instructions in case of emergency please read the safety information available at: <https://www.worldsensing.com/safety-information/>
- In the case of an emergency and after it has been managed, please evaluate the waste generated in order to dispose of it in accordance with current legislation and local regulation.
- It is your responsibility to dispose of your waste equipment, batteries and packaging properly to help prevent potential negative consequences for the environment and human health.
- The cost of environmental waste management is included in the product's selling price.

Implementing these best practices supports environmental conservation, regulatory compliance, and operational sustainability.

Appendix A. Axis convention while installing the device attached vertically and horizontally

Positive and negative angles are presented in our documentation through schematics of the different tiltmeter installation configurations (see Section 11 – Tiltmeter axes orientation).

The axis markings are external and are shown on both the top cover and one lateral face of the tiltmeter. Worldsensing defines that a rotation favoring gravity in the direction indicated by the axis arrow corresponds to a positive angle (or a positive change in angle).

When installing a tiltmeter, we recommend recording the following information in the installation report:

- Sensor coordinates
- Node orientation (vertical or horizontal)
- Direction of one axis relative to magnetic north

We also recommend following a single, consistent installation criterion within a project. For example, in a railway track monitoring installation, all tiltmeters could be installed with the X-axis arrow pointing toward the increasing kilometer point. If, for any reason, tiltmeters must be installed with different orientations, it is important that this is clearly documented in the installation report.

Tiltmeter mounted on a vertical surface

Below is a drawing showing a tiltmeter attached to a vertical structure using the horizontal mounting plate (LS-ACC-IN15-HP) and anchors. The drawing illustrates the different axes of interest and their sign convention for two installation orientations recommended by Worldsensing:

Warning: The axis used to measure inclination in the plane parallel to the vertical surface is different in the two orientations.

- **Orientation 1:** Straight antenna – without using an elbow connector – exiting from the bottom face and pointing downwards.

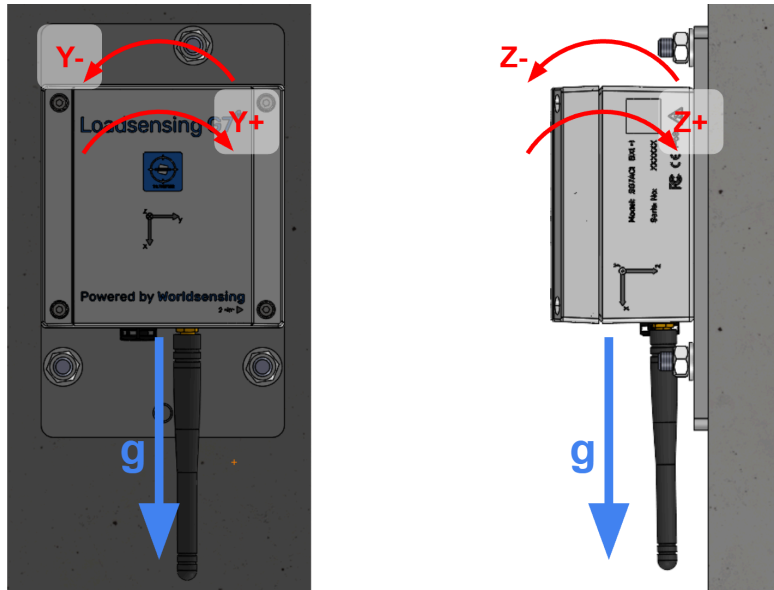

- **Orientation 2:** Antenna using an elbow connector, exiting from a lateral face with the antenna pointing upwards.

Note: This orientation was the standard configuration for the LS-G6-TIL90-X when mounted on a vertical surface.

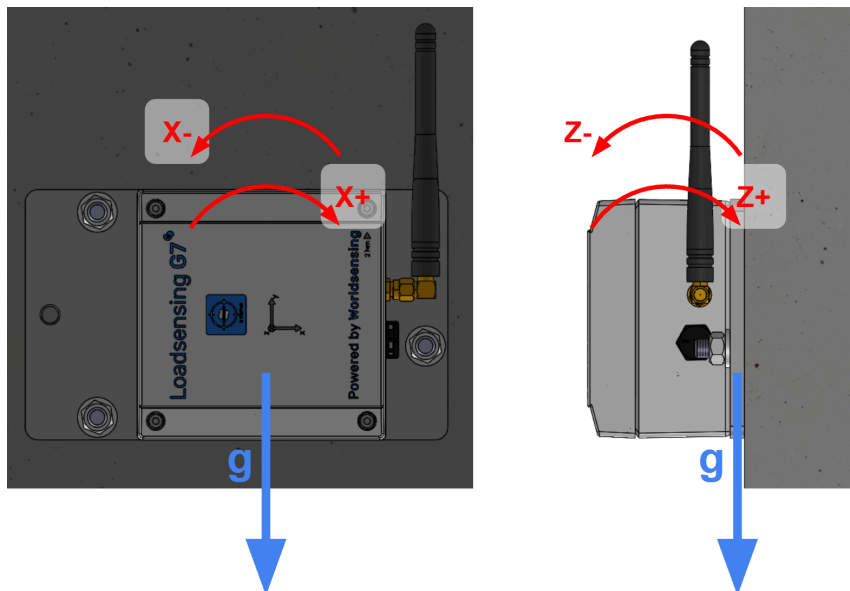

Tiltmeter mounted on a horizontal surface

Also the axes of interest and their sign convention are shown in the image below for mounting the tiltmeter in horizontal position (gravity is also indicated).

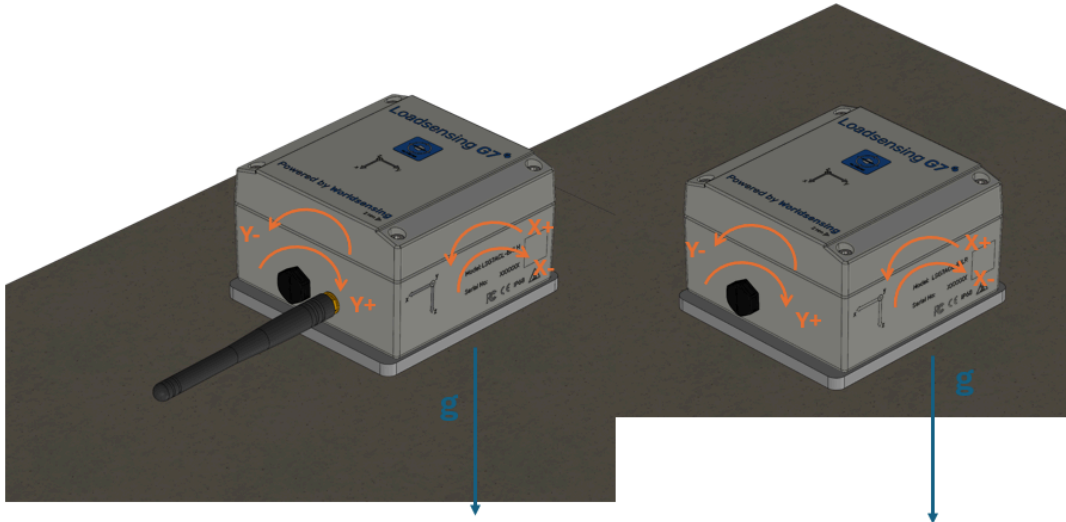

Tilt-IR (LSG7ACL-BILR-TIL) mounted on a horizontal surface

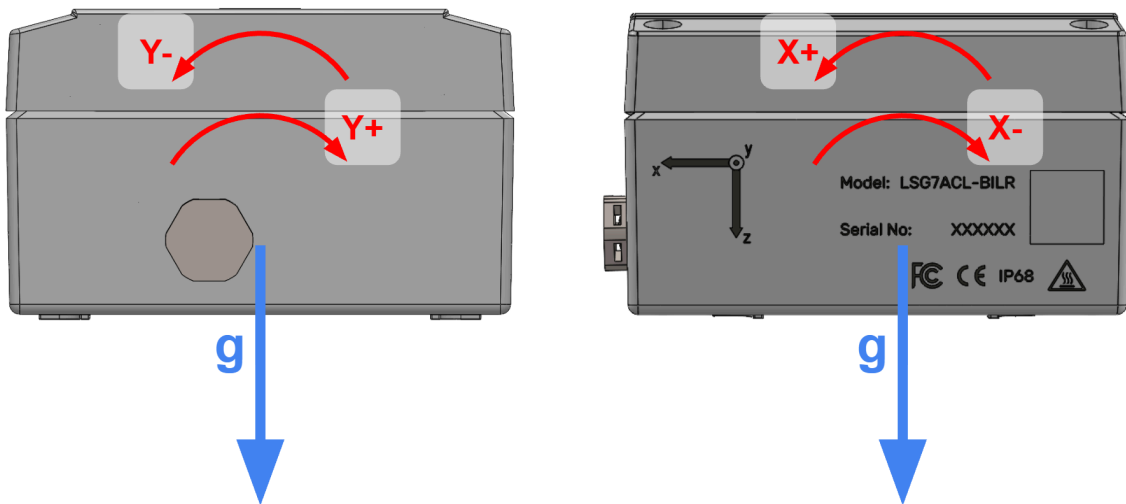

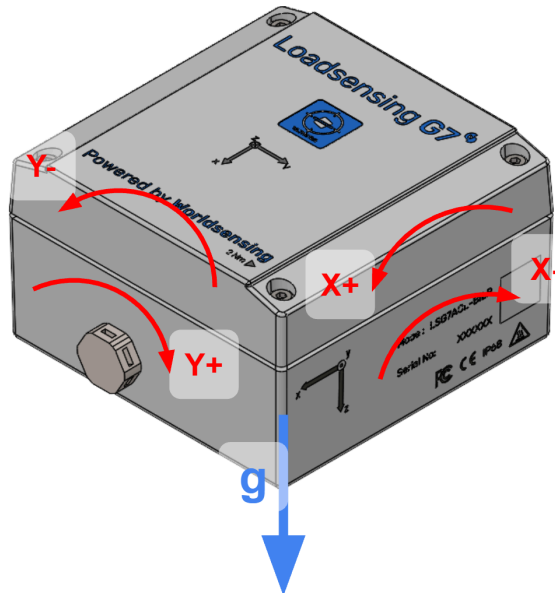

Tilt-XHP (LSG7ACL-BXLH-TIL) mounted on a horizontal surface

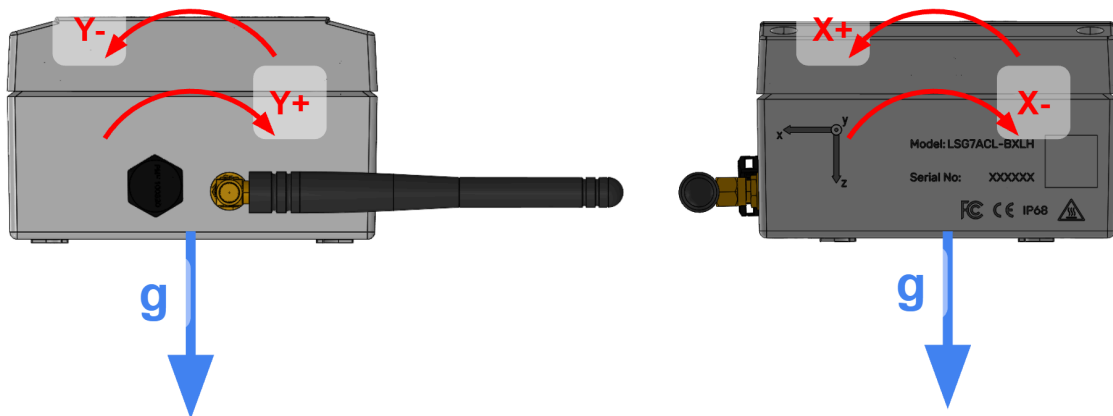

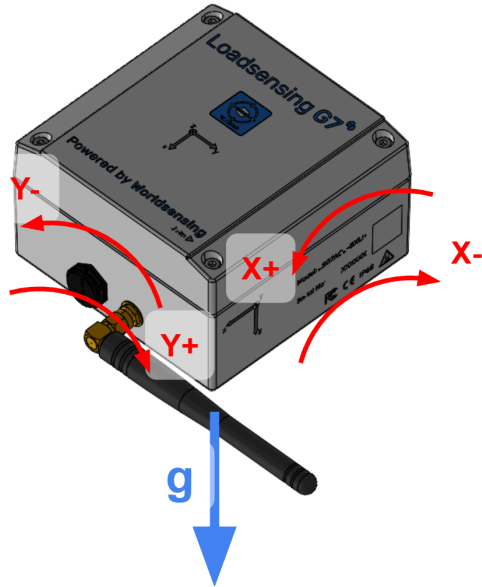

Positive and negative angles on Worldsensing tiltmeters

LS-G6-TIL90-X		Tilt-XHP
Marking 1 (sn < 90805)	Marking 2 (sn >= 90805)	LSG7ACL-BXLH-TIL
<p>sn < 90805</p>	<p>sn > 90805</p>	

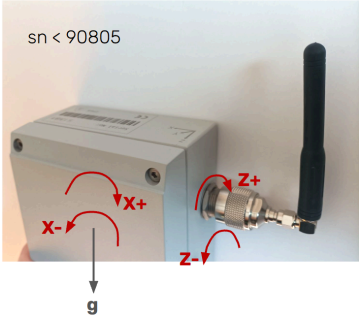
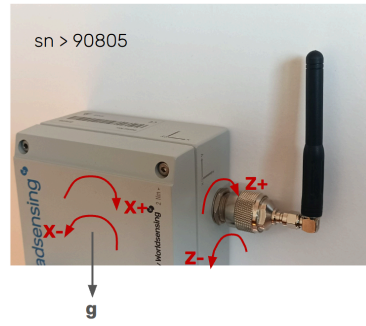
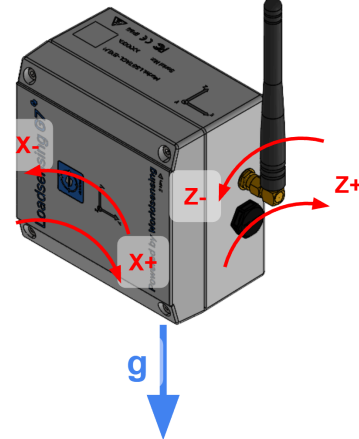
LS-G6-TIL90-X		Tilt-XHP
Marking 1 (sn < 90805)	Marking 2 (sn >= 90805)	LSG7ACL-BXLH-TIL
<p>sn < 90805</p> 	<p>sn > 90805</p> 	

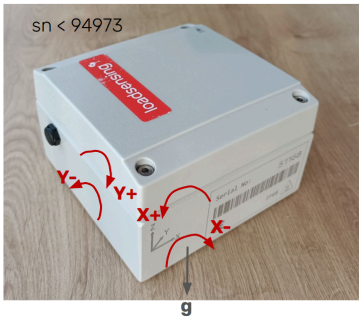
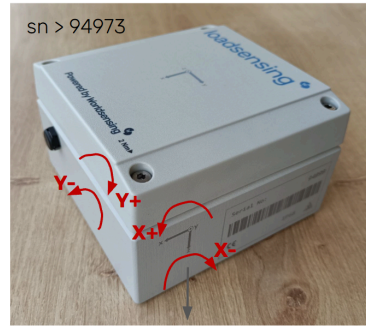
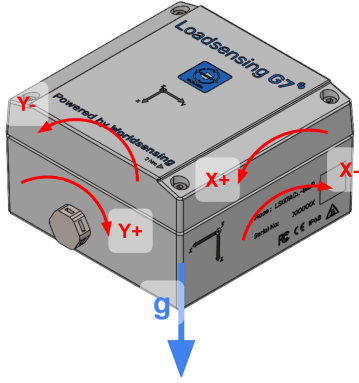
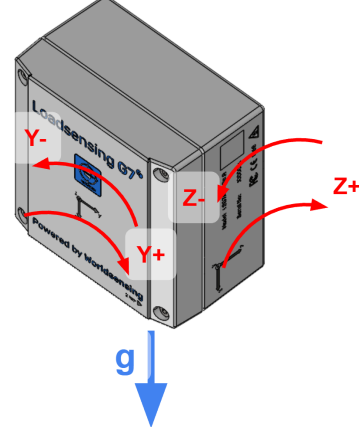
LS-G6-TIL90-I		Tilt-IR
Marking 1 (sn < 94973)	Marking 2 (sn > 94973)	LSG7ACL-BILR-TIL
<p>sn < 94973</p> 	<p>sn > 94973</p> 	
		

Please note that the criteria from TILT-XHP/TILT-IR models has not changed with respect to G6 models and the references to elements such as the antenna, the gore valve or the barcode and the serial number have been maintained.

Appendix B. CALIBRATION SHEET

Loadsensing G7^W

CALIBRATION REPORT



Part Name: LSG7ACL-BXLH-TIL
 SerialNumber: 164371
 DateTime: 22/7/2025 11:43:54 AM
 Script Version: v1
 References: Calibration Station - 2402001
 Temperature: 24.9 °C

Calibration Parameters

The following calibrations formula is already applied to every reading in the sensor

$$A_{calib} = Gain * A_{Axis} + Offset$$

Where,

	Axis X	Axis Y	Axis Z
Gain	1.003531	0.996643	0.994676
Offset	-1854.229298	782.095784	1877.314878

Results

At this point the three axis are calibrated with their given parameters. Shown below are some example data points. These measurements were recorded when the node was rotated on only the Y and Z planes, hence there are no data points for the X axis. Sensor reading values:

Axis Y:

Inclination	Calculated angle	Error Calc
5.0	4.9953	0.0047
45.0	44.9836	0.0164

Axis Z:

Inclination	Calculated angle	Error Calc
85.0	84.8541	0.1459
45.0	44.9905	0.0095

Error After Calibration

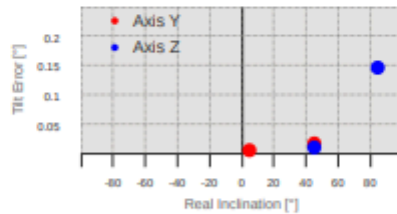

The calibration formula is directly applied to readings collected by the Tiltmeter device. Data transmitted by the node is already corrected. Do not apply the calibration formula again

Authorized signatory:

Ramón Robles
Production Leader

Authorized signatory:

Francisco Hernandez
VP Product & Compliance

Authorized signatory:

Andrea Bartoli

Andrea Bartoli
VP & CTO

CONTACT WORLDSENSING

Need more support?

Get in touch with our Customer Success team:
Email: support@worldsensing.com
Phone: +34 93 418 05 85 (08.30h - 16.30h UTC)

Want to stay up-to-date about Worldsensing?

Sign up for our newsletter: www.worldsensing.com

Visit our Knowledge Center for interesting content:

worldsensing.com/knowledge-center

Follow us online

